

**CORPORATION OF CHENNAI
STORM WATER DRAIN DEPARTMENT
FOR WORKS BELOW 2 CRORES**



TENDER FOR Dismantling 600 x 750 mm and Reconstruction of RCC Box type Storm Water Drain of size 900 x 900mm along Nallaiah Street from Barrakka Road to Subbarayan Main Street in Dn 59, Zone IV.

Letter of Tender, Schedule and Conditions

Superintending Engineer/

DATED 12/11/2010

Storm Water Drain Department

Price: Rs.6750/- (Rupees.....Six thousand seven hundred and fifty only)

(THIS TENDER DOCUMENT IS NOT TRANSFERABLE)

CONTENTS

SL.NO.	DESCRIPTION	PAGE NOS.
1	CONTENTS	2
2	TENDER NOTICE	3
3	CONDITIONS OF CONTRACT	4-14
4	CONTRACT DATA.	15
5	LETTER OF TENDER	16
6	DECLARATION OF THE TENDERER.	17
7	LIST OF EQUIPMENTS, KEY PERSONNEL	18
8	INDEMNITY BOND.	19
9	SCHEDULES	57-63
10	AGREEMENT.	20
11	SECURITY FORMS	21-23
12	DEFINITIONS	24-25

**CORPORATION OF CHENNAI
STORM WATER DRAIN DEPARTMENT**

TENDER NOTICE

Sealed Tenders are invited for the following works as per details furnished below

The Tenderer's may submit separate tenders for each of the following work/works mentioned below:

Sl. No.	Ref No	Name of work	Approx. value of work (Rs.in lakhs)	EMD (Rs.)	Cost of Tender (Rs.)	Eligible Class	Date & Time of Submission
1	PWC No. 3372	Dismantling 600 x 750 mm and Reconstruction of RCC Box type Storm Water Drain of size 900 x 900mm along Nallaiah street from Barrakka Road to Subbarayan main Street in Dn 59, Zone IV	22.39	22400	6750/-	Class III and Above	12.11.2010 at 3.00PM

The Tenders can also be downloaded from website <http://tender.tn.gov.in> and www.chennaicorporation.com or obtained at the Tender Sales Counter, Ripon Buildings. Tenders will be opened on **12.11.2010** at 3.00 p.m. Sale of tender will be closed 48 hours before the time fixed for submission of tender. The tender can be dropped in the tender boxes kept in any one of the offices viz., PRO, C.E. (GI), V.O and Tender Sales Counter.

NOTE: The tender document can also be downloaded from the websites www.tntenders.gov.in or www.tenders.tn.gov.in. The downloaded tender document shall be submitted without cost of tender document. In case of deviation is found in the tender document submitted by the tenderer from the content mentioned in the websites, his tender shall be liable for rejection at any stage of the contract.

If due date of tender happens to be Public Holiday, the tenders will be received up to .3.00. P.M and opened by 3.00 P.M. on the next Working day.

Executive Engineer/SWDD

Superintending Engineer/SWDD

2. CONDITIONS OF CONTRACT

1. The Contractors having registration in the class specified in the tender notice and above in the concerned Department of Corporation of Chennai or intending Tenderer should be a registered contractor in any of the Centre / State Government Department / Government undertaking are eligible to participate in the Tender. Provisional Registration has to be done for the successful bidder if he is willing to abide by the Rules and Regulations of Corporation of Chennai and on payment of prescribed fees..
2. No one or non of a firm or company is eligible to participate in the tender if any one of his or any one or more of the director's of a firm or company is a blood relative of any one of an employee or a public representative of Corporation of Chennai.
3. Corporation of Chennai is not responsible for the risk or risk, cost and responsibility of participation for the tenderer to participate the tender. The tenderer has to participate the tender at the risk, cost and responsibility of his own.
4. The Tenderer, at the Tenderer's own responsibility and risk, is mandatory to inspect and examine the site of proposed tender and its surroundings and collect all information that may be necessary for the Tender prior to participation in the tender at the risk, cost and responsibility of the tenderer.
5. At any time after the issue of the Tender documents and before the opening of the Tender, the Tender inviting authority may make any changes, modifications or amendments to the Tender documents and has to send intimation of such change to all those who have purchased the original Tender documents. Prospective Tenderer's has to promptly acknowledge the receipt thereof in person or by telex, cable or fax, e-mail, telegram, phonogram, post, courier or any other means of communications adopted and approved by Corporation of Chennai. The Tender has to submitted taking into account the addendum/amendments, if any, issued as mentioned above and any failure in doing so will lead to consequences including rejection of Tender.
6. The Tender submitted by the Tenderer has to comprise the following:
 - (a) The Tender;
 - (b) Earnest Money Deposit;
 - (c) Priced Bill of Quantities;
 - (d) Attested Copy of registration certificate;
 - (e) Sales Tax clearance certificate for the current year obtained from the appropriate authority;and any other materials required to be completed and submitted by Tenderer's, as specified by the Tender inviting authority.
7. The Tenderer must enclose Photostat copy of his or her registration certificate of respective class and nature of work along with the Tender or must produce the copy to the Tender opening officer for further processing of tenders.
8. In case of proprietary or partnership firm, it is mandatory to produce the certificate aforementioned for the proprietor or proprietors and for each of the partners as the case may be. If a certificate for the current year had already been produced by the Tenderer during the calendar year in which the tender is made, it will be sufficient if participate in tender. At the time of agreement an undertaken has to be produce with notary attestation that there is no change in the proprietors or partnership and that status will be continued till completion of works. In case of breach, all the monetary benefits are liable to be unpaid and forfeited by Corporation of Chennai.
9. The Contract has to be for the execution of full schedule quantities and not for any portion.
10. All duties, taxes, and other levies payable by the Contractor under the Contract, or for any other cause has to be included in the rates, prices, and total Tender price submitted by the Tenderer.
11. Tenders has to remain valid for a period of 90 days unless otherwise specifically mentioned by the Tender inviting authority.
12. Under unavoidable or In exceptional circumstances, the Authority may request that the Tenderer's to extend the period of validity for a specified additional period as required in public/administrative interest. The request of the authority and the Tenderer's' responses has to be made in writing and in approved means of communications as specified in the tender. A Tenderer may refuse the request without forfeiting the Earnest Money Deposit. A Tenderer agreeing to the request will not be required or permitted to otherwise modify the Tender, but will be required to extend the validity of Earnest Money Deposit for the period of the extension.

13. The Tenderer has to furnish, as part of the Tender, an **Earnest Money Deposit (EMD)** for an amount of Rs.22400/- (Rupees Twenty two thousand and four hundred only). The Earnest Money Deposit has to be either in the form of Demand Draft/ Banker's cheque or Irrevocable Bank Guarantee from any Nationalised/Scheduled Bank in favour of the Commissioner, Corporation of Chennai; Banker's cheque; or a chalan by remitting cash into the Corporation Treasury, to the credit of deposits which do not bear interest. . Tenders not accompanied by the Earnest Money Deposit will be rejected. **Bank guarantee from any Nationalized/Scheduled banks will be accepted, if the work value is more than rupees 25 Lakhs.**
14. The Earnest Money Deposit of the successful Tenderer will be discharged without interest when the Tenderer has signed the Agreement and furnished the requisite Security Deposit.
15. The Earnest Money Deposit will be forfeited:
 - (a) If a Tenderer withdraws his Tender during the period of Tender validity.
 - (b) If a successful Tenderer fails to:
 - i) Execute the agreement or
 - ii) Furnish the necessary security deposit and sign the agreement within the specified time limit 14 days from the date of receipt of letter of acceptance of his Tender.
 - c). If the Tenderer does not accept the correction of the Tender price, pursuant to Clause 25.
16. The entries in the Schedule of the Tender has to be typed or written in legible ink and has to be signed by person or persons duly authorized to sign on behalf of the Tenderer. All pages of the Tender document has to be signed and also where entries or amendments have been made has to be signed by the person or persons signing the Tender.
17. The Tender has to not contain any alterations or additions, except those to comply with instructions issued by the Authority, or as necessary to correct errors made by the Tenderer, in which case such corrections has to be signed by the person or persons signing the Tender.
18. The Tenderer has to be responsible for properly super scribing and sealing the cover in which the Tenders submitted and Tender inviting authority has to not be held responsible for accidental/ misplacement/premature opening of the covers that are not properly super scribed and sealed before the time appointed for Tender opening.
19. The filled up Tender documents has to be submitted up to the last date and time of submissions as specified in the tender notice. Duly filled in Tender documents has to be put in any one of the Tender boxes provided at the Tender Sales Counter, Office of the Public Relation Officer, Office of Vigilance Department and Office of Chief Engineer/General in the Ripon Buildings, Chennai. Tenders can also be submitted by Post or Courier, provided that the Tender inviting authority has to not be held responsible for any delay in transit in such cases.
20. The Tender inviting authority may extend the last date of receiving tenders after giving adequate notice to all intending Tenderer's.
21. The Tenderer's has to not amend/add/alter any of the Tender conditions, conditions of contract, specifications etc. of his own.
22. Any Tender received by the Authority after the deadline prescribed will be summarily rejected.
23. The Tenders will be opened at the time and date specified, in the presence of Tenderer's /authorized representatives who choose to attend. The Tenderer's' names, and the presence or absence of Earnest Money Deposit, Quoted price of each Tenderer and such other details as the Authority may consider appropriate, will be announced by the Authority at the opening.
24. From the time of Tender opening to the time of contract award, if any Tenderer wishes to contact the Authority on any matter related to the Tender, it has to do so in writing.
25. Where there is a discrepancy between the amounts in figures and in words, the lowest will be taken in to grant and the amount stated in the Tender will be adjusted by the Authority in accordance with the above procedure for the correction of errors has to be considered as binding upon the Tenderer. If the Tenderer does not accept the corrected amount, the Tender will be rejected, and the Earnest Money Deposit will be forfeited.
26. The tendered rates for the items should be inclusive of all items of works required for the proper execution of the items in quality, quantity, safety and security in the interest of public as well as administration The rates to be mentioned in the tender has to be inclusive of sales tax and other applicable fees, levies, taxes in force.

27. The Authority reserves the right to accept or reject any Tender, and to cancel the Tendering process and reject all Tenders, at any time prior to the award of Contract in exercise of the power conferred by Section 12 (1) and (2) of Tamil Nadu Transparency In Tender Act,1998 subject to the provisions of subsection 1 and 2 of Section 12 of Tamil Nadu Transparency In Tender Act 1998, without thereby incurring any liability to the affected Tenderer/ Tenderer's any obligation to inform the affected Tenderer / Tenderer's the grounds for the Authority's action.
28. The Tenderer whose Tender has been accepted will be intimated by the Authority prior to expiration of the Tender validity period by cable, telex, or facsimile confirmed by registered letter. This letter (hereinafter and in the Conditions of Contract called the "Letter of Acceptance") will state the sum that the Authority will pay the Contractor in consideration of the execution, completion, and maintenance of the works by the Contractor as prescribed by the Contract (hereinafter and in the Contract called the "Contract Price").
29. It shall be expressly understood by the tenderer that on receipt of written communication of acceptance of tender from the accepting authority, there emerges a valid right of contract between the Commissioner, Corporation of Chennai and the tenderer, for execution of the work without any separate written agreement. Hence for this purpose, the tender document, i.e. tender offered by the contractor, conditions of contract, negotiation, correspondences, written communications of acceptance of tender etc. has to constitute a valid contract and that will be the fundamental of the rights of both the parties of the contract. If the contractor fails to carry out the contract; after paying the requisite deposits, then he will be liable for the excess expenditure if any incurred to complete the work as contemplated in the conditions of the contract.
30. The Tenderer has to enter into an agreement with the Authority within 14 days from the date of receipt of letter of acceptance. The form of agreement should be stamped at the stamp office at the risk, cost and responsibility of the Tenderer.
31. Preliminary specification etc, in SSRB/TNBP will form part of the Agreement. The tenderer has to examine closely" SSRB/TNBP, General conditions to the contract" and also the Standard, preliminary Specifications Contained therein, and sign the SE's / EE's Office copy of the SSRB/TNBP and its addenda volume in token of such study before submitting his tender unit rates, which has to be for finished work in situ. He has to also carefully study the drawings and additional specifications and all the documents which form part of the agreement to be entered in to by the accepted tenderer. The SSRB/TNBP and other documents connected with the contract such as specifications, plans, descriptive specification sheet regarding materials, etc., can be seen at any time between the hours on all working days, in the office of the SE/EE of concerned department/zone of Corporation of Chennai. The Tenderer's attention is directed to the requirements for materials under the clause "Materials and Workmanship in the preliminary Specification. Materials conforming to the IRC/ISI has to be used on the work, and the tenderer has to quote his rates accordingly.
32. Within 14 days after receipt of the Letter of Acceptance, the successful Tenderer has to deliver to the Authority a **Security Deposit**. Security Deposit will be 2% to 5 % as specified in clause 34 for the contract amount in the form of National Savings Certificate/ Small savings instrument/deposits/Accounts pledged in favour of Commissioner, Corporation of Chennai; irrevocable Bank Guarantee/warrantee. However it is open to the Commissioner to insist on higher deposit as per rules in force
- 33.1 As per the Council Resolution No. 584/86 dated 21.05.86; the percentages of security deposit to be fixed for various percentages of rebates are as following.

Percentage Rebate	Percentage of Security Deposit to be fixed
Up to 10 %	2%
10 to 20 %	3%
20 to 30 %	4%
Above 30%	5%

33.2. As per Council Resolution N. 456/2002, Dt : 28-11-2002 the amount of **Additional Security Deposit** to be paid by the Contractor along with the tender for various percentage of rebate are as follows:

Percentage of rebate	Amount of Additional Security Deposit payable in the form of Demand Draft
5 to less than 15%	2%
15% to 20%	50% of Difference between Office value of work and Tender amount.
above 20%	Same as above

33.2.1 The Contractors has to pay the Additional Security Deposit in the form of Demand Draft drawn in favour of Commissioner while submitting the tender documents. **For more than 1 Lakh bank Guarantee will be accepted.**

33.2.2 If any of the Contractors has not enclosed Additional Security Deposit for the appropriate value in the form of Demand Draft while submitting tender documents, the tenders of such Tenderer's will be summarily rejected.

33.2.3 The Demand Draft/Banker's cheque enclosed for the Additional Security Deposit by the unsuccessful Tenders will be returned after obtaining proper acknowledgement and absorbing official procedures..

33.2.4 If percentage of rebate is above 20% tenderer should furnish the break up details, risk, cost and responsibility analysis and produce documents to prove the previous experience and work on hand with performance certificate showing the satisfactory completion of works entrusted in order to substantiate that the quoted rate is workable for complete execution as detailed in tender..

34. The Tenderer has to observe high degree of legal and moral ethics during Tendering process and execution of the Project. The Authority will reject a proposal for award if it determines that the Tenderer recommended for award has engaged in corrupt or fraudulent practices in competing for the contract in question as described below:

(i) "Corrupt practice" means the offering, giving, receiving or soliciting of any thing of value to influence the action of a public official in exercising his official duty regarding the tender and its connected official activities.

(ii) 'Fraudulent practice' means a misrepresentation of facts in order to influence the selection process or the execution of a contract in the detriment of the Authority and includes forming syndicate/consortium or any other collusive practice among the Tenderer's during selection process to fix the prices artificial, non-competitive levels and to deprive the Authority of the benefits of free and open competition.

(iii) The Authority will reject a proposal for award if it determines that the Tenderer recommended for award has engaged in corrupt or fraudulent practices in competing for the contract in question.

35. The Tenderer's who are themselves not professionally qualified, has to undertake to employ qualified technical personnel at their risk, cost and responsibility to execute the work.

36. For works costing Rupees One Lakh and above, preference in selection will be given to the Tenderer's who are themselves professionally qualified or undertake to employ qualified personnel at their risk, cost and responsibility to supervise the work when price quoted are equal among the Tenderer's he Tenderer's should clearly state whether they are professionally qualified and or else produce the credentials of the technical personnel they intend to deploy for the work.

37. The Contractor has to employ technical personnel with qualification and experience specified in the following table at their cost to supervise the work. Penalty at the rate specified in the table has to be levied from the contractor if he fails to adhere to this condition.

Value of Contract in Indian Rupees	Minimum Qualification and Experience of The Technical Personnel to be Deployed for the work	Penalty for not deploying technical personnel with qualification specified in Column. 2
(1)	(2)	(3)
Up to 10 Lakhs	One Diploma holder in Civil Engineering or a Retired Supervisor (Civil) from Government Service or an Autonomous body like Tamil Nadu Housing Board, etc.	Rs. 2000/- per month.
Above 10 Lakhs up to 30 Lakhs.	One B.E. (Civil) or an equivalent Degree holder in Civil Engineering with one year experience or Retired Civil Engineer from Government Service or an Autonomous body like Tamil Nadu Housing Board, etc. not below the rank of an Assistant Engineer.	Rs. 5000/- per month.
Above 30 Lakhs up to 1 crore.	One B.E. (Civil) or an equivalent Degree holder in Civil Engineering with three years experience or Retired Civil Engineer from Government Service or an Autonomous body like Tamil Nadu Housing Board, etc. not below the rank of an Assistant Engineer plus one One Diploma holder in Civil Engineering or a Retired Supervisor (Civil) from Government Service or an Autonomous body like Tamil Nadu Housing Board, etc..	Rs. 5000/- plus Rs. 2000/- per month.
Above 1 crore up to 2 crore.	One B.E. (Civil) or an equivalent Degree holder in Civil Engineering with seven years experience or Retired Civil Engineer from Government Service or an Autonomous body like Tamil Nadu Housing Board, etc. not below the rank of an Assistant Executive Engineer plus One B.E. (Civil) or an equivalent Degree holder in Civil Engineering with one year experience or Retired Civil Engineer from Government Service or an Autonomous body like Tamil Nadu Housing Board, etc. not below the rank of an Assistant Engineer plus two Diploma holders in Civil Engineering or two Retired Supervisors (Civil) from Government Service or an Autonomous body like Tamil Nadu Housing Board, etc..	Rs. 7000/- plus Rs. 5000/- plus Rs. 2000/Each supervisor, per month.

38. The Contractor has to comply with the provisions of the Apprentices Act, 1961 and the rules and orders issued there under from time to time. If the Contractor fails to adhere to this condition, the competent authority may at his discretion cancel the contract or invoke any penalty at his discretion.
39. The contractor has to, during the performance of the contract, engage apprentices in the categories mentioned in the table below and make payments as required under the Apprentices Act, 1961.

Value of Contract in Indian Rupees	Category of Apprentice	Number to be Engaged
Above 1 Lakh up to 3 Lakhs	1. Building Constructor	1
	2. Brick Layer	1
Above 3 Lakhs up to 10 Lakhs	1. Building Constructor	1
	2. Brick Layer	1

	3. Diploma Holder in Civil Engineering	1
Above 10 Lakhs up to 50 Lakhs	1. Building Constructor 2. Brick Layer 3. Degree holder in Civil Engineering	1 1 1

40. The contractor has to employ one ITI trained mason/electrician for every ten masons or part thereof. In case of non availability of ITI trained masons/electricians, the contractor has to obtain the prior approval of the Executive Engineer concerned before proceeding with the contract with the other kinds of masons/electricians.
41. If the Authority instructs the contractor not to engage any one or more of employee/worker who misbehaves, the contractor has to not engage such person/s with instant effect until the completion of the contract work.
42. The contractor has to commence the work within 7 days from the date of handing over of site to the contractor and has to complete the work within the time limit specified therein the contract agreement.
43. No part of the contract shall be sub-let without written permission of the Superintending Engineer of concerned Department in the case of capital in the case of Zone, the Zonal Officer and no transfer shall be made by power of attorney authorizing others of receive payment on contractor's behalf.
44. A detailed statement showing the particulars of equipments, resources and key personnel owned/hired by the tenderer required for the execution and completion of the work has to be enclosed with the tender.
45. The contractor has to make his own arrangement for all the tools, plants, machineries and man power required for the execution of the work. The corporation will not have any responsibility liability in this regard.
46. The contractor has to make his own arrangement in consultation with the authorities concerned for forming and maintaining traffic diversion that includes formation of diversion roads for free flow traffic during the execution of work and for that no additional payment will be made.
47. As soon as the contract is accepted, the Contractor should give a program of work based on CPM and PERT charts which he proposes to adopt for execution. The Contractor has to commence execution of the works on the start date and has to carry out execution in accordance with the Program submitted by the Contractor, as updated with the approval of the authority, and complete them by the Intended Completion Date.
48. The Contractor has to submit the personal accident/general/medical/Insurance for the personnel/ machineries to be engaged by the contractor for execution of the work prior to commencement of the work and concerned insurances has to be kept in live condition until the completion of the work. Payment will not be made in case of the insurances are not kept in live condition.
49. The Contractor has to execute the works in accordance with the Specification and Drawings as approved by the authority.
50. The opening function expenses of the newly constructed structure by the Corporation of Chennai including the tablet stone has to be borne by the contractor concerned.
51. The Contractor is solely responsible for the quality, quantity, safety and security of all activities at the site of work as well as the locations connected with the work.
52. The Time Schedule will commence from the date of service of the work order or the time allowed by the authority in the work order issued to the contractor.

53.1 Table for Time Schedule of various works-below 2 crores.

1	Bridges-below -2 crore	6 months
2	Roads-up to 15 lakh	1 month.
3	Roads-above 15 lakh to 30 lakh.	2 month
4	Roads- Above-30 lakh to 75 lakh	3 months
5	Roads- Above -75 lakh up to 2 crore.	Will be fixed by respective H.O.Ds depending on works
6	SWD-up to 15 lakh	2 months
7	SWD-above 15 lakh-up to 30 lakh	3 months
8	SWDE-above 30 lakh up to 75 lakh	5 months
9	SWD-above 75 lakh up to 2 crore	6 months
10	Buildings up to 15 lakh	4 months
11	Buildings- above 15 lakh up to 30 lakh	6 months
12	Buildings-above 30 lakh up to 75 lakh.	9 months
13	Buildings above 75 lakh up to 2 crore	Will be fixed by respective H.O.D's depending on works.

Table for forming works

Contract Amount.	Forming Work of Roads	Foot-path.	Electrical
Up to 15 lakh	2 months	2 months	2 months.
Above 15 lakh and up to 30 lakh.	3months	3 months	3 months.
Above 30 lakh and up to 75 lakh	5 months	5 months.	5 months
Above 75 lakh and up to 2 crore	Will be fixed by respective H.O.D.s depending on works.	Will be fixed by respective H.O.D.s depending on works.	Will be fixed by respective H.O.D.s depending on works.

53.2 .If the contractor fails to complete the works as per and within the time schedule or extension of time allowed by the Authority, due to failure attributable to the contractor, the contractor has to pay or allow the Corporation to levy the amount mentioned in the table below as liquidated and ascertained damages for every day beyond the said date or extended time as the case may be during which the works has to remain incomplete. Liquidated and ascertained will be levied as detailed below.

Liquidated and Ascertained Damages

The liquidated damage and ascertained damages will be levied at the rate of 0.05% (zero point zero five percentage) of the contract value of the work per day till it reaches the

maximum value of 5% (five percentage) of the contract value of the work. If the contractor fails to complete the work even then, action will be taken to terminate the contract and execute the work at his risk and cost as per provisions of the general conditions of contract of T.N. B.P, besides debarring the contractor for a specified period by the competent Authority

Table for Liquidated and Ascertained Damages per day.

Up to 15 lakhs	Rs. 500/-
Above 15 lakhs and up to 30 Lakhs	Rs. 750/-
Above 30 lakhs.	Rs. 1000/-

54. Non-tendered items: Non tendered items of work up to 25 % of contract value can be carried out without supplemental Agreement. 25% variation in the quantity at the tender awarded rate can be carried out, with the approval of the Commissioner.

For items of work for which the rates can be derived from the rates of the items in the original agreement, the rates will be derived by applying the overall tender premium or discount to the rates for the new item by applying the prorated excess or discount for the item of work, from which the rate is derived; the lesser rate of these two will be adopted for making payment to the contractor.

For items of work for which the rates cannot be derived from the rates for the items in the original agreement, the rates for payment will be as follows:

- (i) When the schedule of rates has not changed during the period from the date of execution of the original agreement to the date of supplemental agreement the rates for the supplemental agreements has to be the prevailing schedule of rates with the tender Premium or Discount applied.
- (ii) When the schedule of rates has changed during the intervening period, the rates arrived at as per the new schedule of rates at the time of execution of the supplemental agreements will be adopted with no tender premium or discount applied to this rate.

55. The value of work executed has to be determined by the Authority. The value of work executed has to comprise the value of the quantities of the items in the Bill of Quantities completed. The Authority may exclude any item certified in a previous certificate or reduce the proportion of any item previously certified in any certificate in the light of later information.

56. **Payment** will be made to the contractor by preparing bills/part bills on request of the contractor at an interval not less than 14 days of previous bills subject to a maximum 90% of the complete value of work. Remaining 10% will be withheld and retained as security for the due fulfillment of the contract. Under the certificate to be issued by the Authority on the completion of the entire works the contractor will receive the final payment of the money due or payable to him under or by virtue of the contract as per condition 55 provided there is no recovery from or forfeiture by the contractor to be made under clause 57 of general conditions of contract of T.N.B.P. Payments has to be adjusted for deductions for retention and other recoveries in terms of the contract and deduction at source of taxes as applicable under the law.

57. **Maintenance Period:** - The contractor has to maintain the works executed by him in proper repair for the period as specified below:

(a) Cement Concrete Roads:

The contractor has to maintain the works executed by him in proper position by attending the repair for a period of 5 years from the date of completion of work, in satisfactory condition at his own risk, cost and responsibility 2.5% of the total value of the work has to be retained for a period of 5 years from the date of completion of work, in order to enable the department officers to observe the effect of work on all seasons up to five years.

(b) Buildings, Bridges & Storm Water Drains:

The contractor has to maintain the works executed by him in proper position by attending the repair for a period of 2 years from the date of completion of work, in satisfactory condition at his own risk, cost and responsibility. 2.5% of the total value of the work has to be retained for a period of 2 years from the date of completion of work, in order to enable the department officers to observe the effect of work on all seasons up to two years. An indemnity bond for a further period of 3 years has to be produced by the contractor in the form approved by the Government in G.O. Ms No. 654 dated 15-4-1988 of P.W.D.,

(c)Upgrading and/or strengthening Bus route roads and Interior roads, Private streets, Layout roads and Traffic Improvements:

The contractor has to maintain the works executed by him for a period of 3 (three) years from the date of completion of work in satisfactory condition at his own risk, cost and responsibility. 2.5 percent of total value of work has to be retained for a period of 1 year from the date of completion of work in order to enable the department officers to observe the effect of work on all seasons. As per the Council Resolution No. 94/2007 dated 24.04.2007 , an Indemnity Bond for the period of 2 (Two) years should be obtained from the contractor in the form approved by the Government., so that the contractor has to make good the loss or damage that may be caused to the Corporation of Chennai in respect of rectification of any defect noticed due to the faulty workmanship by the contractor substandard materials used by the contractor in the execution of the work, at his own risk, cost and responsibility.

(d) Laying / Relaying of wearing course for Bus route roads, Interior roads, Private streets and Layout roads:

The contractor has to maintain the works executed by him in proper repair for a period of 3 (Three) years from the date of completion of work, in satisfactory condition at his own risk, cost and responsibility. 2.5% of the total value of the work has to be retained for a period of 1 (one) year from the date of completion of work, in order to enable the department officers to observe the effect of work on all seasons. As per the Council Resolution No. 94/2007 dated 24.04.2007, an Indemnity Bond for the period of 2 (Two) years should be obtained from the contractor in the form approved by the Government.

In all above 4 categories of works, the security deposit will however be refunded after the expiry of 6 months from the date of completion of the work.

(e) Guarantee Period of Vehicles/Materials for Mechanical Department:

The tender/supplier/manufacturer has to furnish specific guarantee/warranty for the vehicles/equipments/spares/materials/equipments/spares supplied which is applicable and acceptable by all State Government Departments of Tamil Nadu Government In addition to adequate pollution control norms and registrations if and as applicable. In addition to specific guarantee/warranty period a maintenance period beyond of 6 months for vehicles/equipments/spares supplied beyond the guarantee/warranty period has to be guarantee by the tenderer/supplier/manufacturer. Any failure/defects noticed within the guarantee/warranty period as well as within the maintenance period, the company has to replace the supplied items/ at free of cost at the risk, cost and responsibility of the tenderer/supplier/ manufacturer. For any delay in effecting the supply beyond the delivery period a penalty of minimum Rs.100/-per day of delay has to be imposed. In case of advance payment made if delay noticed beyond delivery period, in addition to penalty Rs. 100/- per day, interest will be levied as fixed by Corporation of Chennai depending on the applicable higher of interest in force.

(f) Guarantee Period for Electrical Department

The entire installation bearing the fitting and lamp should cover a guarantee/warranty period for 1 year. During this period any fault/failure noticed in the material supplied has to be replaced for rectified by the contractor within 48 hours of receiving such intimations in verbal or in writing whichever is earlier. Failing which the security deposit and retention amount will be forfeited by the Corporation and action will be taken to black list the contractor. The percentage of excise duty, sales tax, surcharge on S T. for the item offered if any extra has to be mentioned clearly in the offer. Any defects noticed within the said period of maintenance from the date of final super check measurements has to be made rectified by the contractor with his own personal arrangements.

58.a. Adjudicator.

The Commissioner will propose the person to be appointed as Adjudicator under the Contract and stipulated in the Letter of Acceptance.

58. b: Arbitration

In case of any dispute or difference between the parties to the contract either during progress or after the completion of the work or after the termination, abandonment, or breach of contract or as to any matter or thing arising there under except as to the matters left to the sole discretion of the Authority as to the withholding by the Authority of payment of any bill to which the contractor may claim to be entitled, then either party has to forthwith give to the other, notice of such dispute or difference has to be referred to the Arbitrator and the award of such Arbitrator has to be Final binding on the parties, progress of work has to not be suspended or delayed on account of the reference of the dispute to arbitration under this clause.

Either faction within a period has to be fixed by the arbitration file before the arbitration statement of the case and also has to all documents relating to or having a hearing on the case. The Arbitrator has to not be bound to observe the ordinary rules of procedure applicable to trials before judicial Tribunals nor to hear or receive formal evidence, but may pass an award on the documents and statements of the case filed by the parties or personal inspection or on both. The Arbitrator has to have power to view the subject matter of the dispute with or without the parties or their agents to open review and revise any certificate, opinion decision, requisition or notice have in regard to the matters, expressly examined and to determine all matters in dispute which has to be submitted to him and of which notice has been given as aforesaid, in the same manner as if no such certificate, opinion, decision, requisition, or notice been given.

The expenses of such reference to Arbitration has to be awarded by the Arbitrator in his discretion subject to the condition that the amount of expenses awarded to either party has to not exceed the limits set forth, irrespective of the actual expenses incurred by either party. The arbitrator may determine the amount of expenses to be awarded or direct the same to be shared as between solicitor and client or as party, and party and has to direct by whom and to whom and what manner the same has to be borne and paid.

The limits referred in this clause are 5 % monitory award which does not exceeds Rs. 10,000/-, 3 % on which next Rs.40, 000/- or any part thereof, 2 % on the next Rs.50, 000/- or any part thereof.

59 Compensation Events

The following are Compensation Events unless they are caused by the Contractor.

- (a) The Authority does not give access to a part of the Site mentioned in the current milestone.
- (b) The Authority modifies the schedule of other contractors in a way which affects the work of the contractor under the contract.
- (c) Ground conditions are substantially more adverse than could reasonably have been assumed before issuance of Letter of Acceptance from the information issued to Bidders (including the Site Investigation Reports), from information available publicly and from a visual inspection of the Site.
- (d) The Engineer gives an instruction for dealing with an unforeseen condition, caused by the Authority, or additional work required for safety or other reasons.
- (e) Other contractors, public authorities, Utilities or the Authority do not work within the dates and other constraints stated in the Contract, and they cause delay or extra cost to the Contractor.
- (f) The advance payment is delayed.
- (g) The effect on the Contractor of any of the Authority's Risks.
- (h) Other Compensation Events listed in the Contract Data or mentioned in the Contract.

If a Compensation Event would prevent the work being completed before the intended completion data, the intended completion date is extended. The Engineer has to decide by how much the intended completion date has to be extended.

As soon as information demonstrating the effect of each Compensation Event upon the Contractor's forecast. It is to be assessed by the Engineer. If the Contractor's forecast is deemed unreasonable, the decision of the Engineer is final binding on the contractor. The Engineer will assume that the Contractor will react competently and promptly to the event.

The Contractor has to not be entitled to compensation to the extent that the Authority's interests are adversely affected by the contractor not having given early warning or not having cooperated with the Engineer.

CONTRACT DATA

3.1 The Authority is
The Superintending Engineer,
Storm Water Drain Department,
Corporation of Chennai,
Ripon Building,
Chennai -3

The name and identification number of the Contract is
PWC No 3372, SWD C No B5/1184/2010

The works consists of
Dismantling 600 x 750 mm and Reconstruction of RCC Box type Storm Water
Drain of size 900 x 900mm along Nallaiah street from Barrakka Road to
Subbarayan main Street in Dn 59, Zone IV.

The intended completion period for the whole of the works has to be **3 Months**

Sl. No.	Description of Work	Progress stage I (1 Month from Start Date)	Progress stage II (2 Months from Start Date)	Progress stage III (3 Months from Start Date)
1	Reconstruction of SWD 900x900mm	40%	70%	100%

The following documents also form part of the Contract:

1. The Tender;
2. Earnest Money Deposit;
3. Priced Bill of Quantities;
4. Attested Copy of registration certificate;
5. Sales Tax clearance certificate for the current year obtained from the appropriate authority;

3.2 The maintenance period has to be *as per 57b of Conditions of contract.*

4. LETTER OF TENDER SUBMISSION

Ref. No.

Place:

Date:

From

.....
.....
.....

To

The
Corporation of Chennai,
Chennai.

Sub: Submission of Tender No., for the Contract for the
work of "...[Insert Name of the work]....."

Ref: Your Tender Notice No. ...[Insert tender notice no.]... dated

Sir,

1. I / We on behalf
of, as their duly authorized person(s) in my / our official capacity as
of the aforesaid firm, hereby submit this Tender for your consideration. I / We have read and
understood all conditions of this document in full spirit and meaning. I / We hereby agree to
accept all the conditions put forth in this document without any deviations or with the exceptions
which may be expressly admitted and accepted by the Tender accepting authority before the
award of work. The Tender submitted is fully in accordance with the Tender and I / we agree to
all conditions specified in the Tender.

2. Attached herewith are the following:

- i) Income Tax and Sales Tax clearance certificates for the current year issued by the appropriate authority.
- ii) Copy of the class registration certificate for scheduled contractor.
- ii) Demand Draft towards cost of Tender documents in case the documents are downloaded.
- iii) Earnest Money Deposit for Rs..... in the form of:
 - a) Demand Draft (furnish details of the Demand Draft).....
 - b) Chalan (furnish details of the Chalan).....
 - c) Bank Guarantee (Furnish Details)
 - d) Any other relevant Form (Furnish Details)

3. The undersigned declare that the statement made and the information provided in the duly completed Tender are complete, true, and correct in every detail.

Yours faithfully,

(Office seal)

Signature with Name & Designation

5. DECLARATION BY THE TENDERER

I/We _____ hereby declare that I/We am/are not in any way related to any officer who is in charge of.....or having control of this work. I/We agree that if, at any stage, it is found that this declaration is untrue, the Earnest money Deposit/Security Deposit paid by me/us will be forfeited and the contract entered will stand cancelled at the risk and cost of contractor.

Signature of the Tenderer

Place:

Date:

6. List of Equipment along with copies of attested documents for ownership filled by the Contractor and submitted along with the tender as per Clause 44)

6.1 Equipments

Sl. No.	Particulars of Equipment	Capacity	Number

6. A.Key Personnel to be deployed by the Contractor for the work.

6.2 Key Personnel

Sl. No.	Position	Qualification	Number	Total Experience	Experience in similar Works

6.3 Other Information if any

7. INDEMNITY BOND

This deed of indemnity executed at (place) on this day of (month)(year).....by Thiru / Tmt / Selvi.....(Name) Widow / Son / Daughter of Thiru.....residing at.....(full address) (hereinafter called Contractor which expression has to unless excluded by or repugnant to the context include his/her heirs, executors, administrators and legal representatives) to and in favor of the Commissioner, Corporation of Chennai, (hereinafter called the "Commissioner" which expression has to unless excluded by or repugnant to the context include his successors and assigns)

Whereas the contractors has submitted the tender for Description of work (place of work of supply) and such tender has been accepted subject to the general conditions to contract appended to the preliminary specification of the T.N.B.P/S.S.R.B and such other conditions issued along with tender documents.

And whereas in pursuance of the terms of contract, that a sum equal to 2 1/2% of the total value of work done, have been retained with the Corporation of Chennai for a period of years reckoned from the date of completion of the work in order to enable the departmental officers to watch the effect of all seasons on the work and the structural stability of the work executed by the contractors;

And whereas it was decided to refund the said sum equal to 2 1/2% of the total value of the work done retained with the Commissioner, Corporation of Chennai on the expiry of period of years reckoned from the date of completion of work provided that the contractor executes an indemnity bond for a period of years indemnifying the Commissioner, Corporation of Chennai against any loss of expenditure incurred to rectify any defect noticed against the specifications mentioned in the tender in the execution of the work or during the period of years.

Now, this deed of indemnity witness that in consideration of the contract entrusted to the contractor by the Commissioner, Corporation of .Chennai, the contractor has agreed to the following terms and conditions and executed this indemnity bond in conformation of all and undertakes to comply with the terms herein below mentioned.

'The contractor doth hereby indemnify the Commissioner, Corporation of Chennai against any loss or damage that may be caused any defect noticed against the specifications mentioned in the tender in the execution of the work entrusted to the contractor during the period of..... Years i.e from upto(dates to be specified).

In witness thereof Thiru / Tmt / Selvithe contractor has signed this deed in the presence of the.....

First Witness:

Second Witness:

Signature of the contractor

9. AGREEMENT

This Agreement, made the [day] day of [month], [year] between [name and address of Authority] (hereinafter called "the Authority") and [name and address of Contractor] (hereinafter called "the Contractor") of the other part.

Whereas the Authority is desirous that the Contractor execute [name and identification number of Contract] (hereinafter called "the Works") and the Authority has accepted the Bid by the Contractor for the execution and completion of such Works and the remedying of any defects therein as per specifications contained in this contract.

Now this Agreement witnesseth as follows:

1. In this Agreement, words and expressions has to has the same meanings as are respectively assigned to them in the Conditions of Contract hereinafter referred to, and they has to be deemed to form and be read and construed as part of this Agreement.
2. In consideration of the payments to be made by the Authority to the Contractor as hereinafter mentioned, the Contractor hereby covenants with the Authority to execute and complete the Works and remedy any defects therein in conformity in all respects with the provisions of the Contract.
3. The Authority hereby covenants to pay the Contractor in consideration of the execution and completion of the Works and the remedying of defects wherein the Contract Price or such other sum as may become payable under the provisions of the Contract at the times and in the manner prescribed by the Contract.

In Witness whereof the parties thereto have caused this Agreement to be executed the day and year first before written.

The Common Seal of _____

was hereunto affixed in the presence of: _____

Signed, Sealed, and Delivered by the said _____

in the presence of: _____

Binding Signature of Authority _____

Binding Signature of Contractor _____

**10. SECURITY FORMS
FORM OF ADVANCE PAYMENT GUARANTEE**

(Bank Guarantee)

(On non-judicial stamp paper of the appropriate value in accordance with stamp Act. The stamp paper to be in the name of Executing Bank. The executing Bank has to be from a Nationalized/Scheduled Bank in India having a net worth of more than Rupees Five billion)

Ref.No.....

Date.....

The Commissioner
Corporation of Chennai
Ripon Building, Periyar EVR Salai
Chennai – 600 003

Dear Sir,

Reg : Bank Guarantee- for the work issued- Reg.

In consideration of Corporation of Chennai (hereinafter referred to as the "Authority" which expression has to, unless repugnant to the context or meaning thereof include its successors, administrators and assigns), having awarded to (Name of the Contractor) (hereinafter referred to as the "Contractors" which expression has to unless repugnant to the context or meaning thereof, include its successors, administrators, executors and assigns), a contract by issue of Authority's Contract Agreement dated and the same having been unequivocally accepted by the Contractor resulting in a Contract valued at for

Name of Work:

(hereinafter called the "Contract") and the Authority having agreed to make (scope of work) an advance payment to the Contractors for performance of the above Contract amounting to (in words and figures) as an advance against Bank Guarantee to be furnished by the Contractors.

We(Name of the Bank), having its Head Office at (hereinafter referred to as the "Bank", which expression has to, unless repugnant to the context or meaning thereof, include its successors, administrators, executors and assigns), do hereby guarantee and undertake to pay the Authority immediately on demand and or, all monies payable by the Contractors to the extent of as aforesaid at any time up to @* without any demur, reservation, contest, recourse or project and/or without any reference to the Contractors. Any such demand made by the Authority on the Bank has to be conclusive and binding notwithstanding any difference between the Authority and the Contractors or any dispute pending before any Court, Tribunal, Arbitrator or any other authority, we agree that the Guarantee herein contained has to be irrevocable and has to continue to be enforceable till the Authority discharges this guarantee.

The Authority has to have the fullest liberty without affecting any way the liability of the Bank under this guarantee, from time to time to vary the advance or to extend the time for performance of the Contract by the Contractors. The Authority has to have the fullest liberty without affecting this guarantee/warrantee, to postpone from time to time the exercise of any powers vested in them or of any right which they might have against the Authority and to exercise the same at any time in any manner, and either to enforce or to forbear to enforce any covenants, contained or implied, in the Contract between the Authority and the Contractors any other course or remedy or security available to the Authority. The Bank has to not be relieved of its obligations under these presents by any exercise by the Authority of its liberty with reference to the matters aforesaid or any of them or by reason of any other act of forbearance or other acts of omissions or commission on the part of the Authority or any other indulgence shown by

the Authority or by any other matter or thing whatsoever which under law would but for this provision have the effect of relieving the Bank.

The Bank also agrees that the Authority at its option has to be entitled to enforce this Guarantee/warranty against the Bank as a principal debtor, in the first instance without proceeding against the Contractors and notwithstanding any security or other guarantee the Authority may have in relation to the Contractors liabilities.

Notwithstanding anything contained herein above our liability under this guarantee is limited to and it has to remain in force up to and including @* and has to be extended from time to time for such period (not exceeding one year), as may be desired by (Name of the Contractor)

Dated this day of 20 at

WITNESS (Signature) (Name) (Office Address) (Signature of authorized Bank Official) (Name) (Designation with Bank stamp) Power of Attorney (To be enclosed) Power of Attorney No Date
---	--

@ The date will be ninety (90) days after the date of completion of Contract.

FORM OF BID SECURITY (BANK GUARANTEE)

WHEREAS, (Name of Bidder) (hereinafter called "the Bidder") has submitted his bid dated (Date) for the {Name of Work)
.....(hereinafter called "the Bid").

KNOW ALL MEN by these presents that We (Name of Bank) of (Name of Country) having our registered office at (hereinafter called "the Bank") are bound unto (Name of Authority) (hereinafter called "the Authority") in the sum of for which payment well and truly to be made to the said Authority the Bank binds himself, his successors and assigns by these presents.

SEALED with the Common Seal of the said Bank this day of 20.....

THE CONDITIONS of this obligation are :

- (1) If the Bidder withdraws his Bid during the period of bid validity specified in the Form of Bid: or
- (2) If the Bidder does not accept the correction of arithmetical errors of his bid price in accordance with the instruction to Bidders: or
- (3) If the Bidder having been notified of the acceptance of his Bid by the Authority during the period of bid validity :
 - a. Fails or refuses to execute the Form of Agreement in accordance with the instructions to Bidders, if required : or
 - b. Fails or refuses to furnish the Performance Security, in accordance with the Instructions to Bidders; or
 - c. Fails or refuses to furnish the Domestic Preference Security, where required.

We undertake to pay to the Authority up to the above amount upon receipt of his first written demand, without the Authority having to substantiate his demand, provided that in his demand the Authority will note that the amount claimed by him is due to him owing to the occurrence of all of one or more of the above conditions, specifying the occurred condition or conditions.

This Guarantee will remain in force up to and including the date of 162 days after the deadline for submission of bids as such deadline is stated in the Instructions to Bidders or as it may be extended by the Authority, notice of which extension(s) to the Bank is hereby waived. Any demand in respect of this Guarantee has to reach the Bank not later than the above date.

DATE..... SIGNATURE OF THE BANK.....

SEAL OF THE BANK.....SIGNATURE OF THE WITNESS.....

Name and address of witness

Definitions.

1. **Act** means the Tamil Nadu transparency in Tenders Act, 1998 (Tamil Nadu Act 43 of 1998).
2. **Rules** means The Tamil Nadu Transparency In Tender Rules, 2000
3. **Adjudicator:** The Commissioner will propose the person to be appointed as Adjudicator under the contract in the Letter of Acceptance.
4. **Arbitrator:** If a party is dissatisfied with the decision of the Adjudicator or no decision is given within the time set out the party may give notice of dissatisfaction and a dispute which has been the subject of a notice of dissatisfaction has to be finally settled by Arbitral tribunal. The Arbitrator can revise the decision of the Adjudicator. The Arbitral Tribunal consists of 3 Arbitrators, one each to be appointed by the Authority and the Contractor. The third Arbitrator has to be chosen by the two Arbitrators so appointed by the parties and has to act as presiding arbitrator. In case of failure of the two arbitrators appointed by the parties to reach upon a consensus within period of 30 days from the appointment of the arbitrator appointed subsequently, the Presiding Arbitrator has to be appointed by President of the Institution of Engineers (India).
5. **The Authority** (Commissioner) or his authorised representative is the party who Employs the Contractor to carry out the Works
6. **Earnest Money Deposit** means the amount required to be remitted by a bidder along with his bid indicating his willingness to implement the contract.
7. **Bill of Quantities** means the priced and completed Bill of Quantities forming part of the Bid.
8. **BIS** means Bureau of Indian Standards.
9. **Compensation Events** are those defined in Clause 59 hereunder.
10. **The Completion Date** is the date of completion of the Works as certified by the Superintending Engineer / Zonal Executive Engineer, in accordance with Sub-Clause 53.1.
11. **The Contract** is the Contract between the Authority and the Contractor to execute, complete, and maintain the Works. It consists of the documents listed in Clause 1.1.11 below.
12. **The Contractor** is a person or corporate body whose Bid to carry out the Works has been accepted by the Authority.
13. **Tenderer Or Bidder:** Any person , firm or Corporation submitting a tender for the work contemplated, acting directly or through a duly authorized representative.
14. **The Contractor's Bid** is the completed bidding document submitted by the Contractor to the Authority.
15. **Bid Price** : The prices and discounts quoted by the bidder in the letter of bid and in the bill of quantities.
16. **The Contract Price** is the price stated in the Letter of Acceptance and thereafter as adjusted in accordance with the provisions of the Contract.
17. **Days** are calendar days; months are calendar months.
18. **A Defect** is any part of the Works not completed in accordance with the Contract.
19. **The Defects Liability Certificate** is the certificate issued by Superintending Engineer upon correction of defects by the Contractor.
20. **The Defects Liability Period** is the period named **in the Contract Data and calculated from the Completion Date**.
21. **Drawings** include calculations and other information provided or approved by the Superintending Engineer for the execution of the Contract.
22. **The Authority** (The Commissioner) is the party who employs the Contractor to carry out the Works

23. **The Superintending Engineer** is the person named in the Contract Data (or any other competent person appointed by the Commissioner and notified to the Contractor, to act in replacement of the Superintending Engineer) who is responsible for supervising the execution of the Works and administering the Contract.
24. **The Executive Engineer** is an Executive Engineer of Corporation of Chennai, who will be in charge of work in Corporation of Chennai.
25. **Equipment** is the Contractor's machinery and vehicles brought temporarily to the Site to construct the Works.
26. **The Initial Contract Price** is the Contract Price listed in the Authority's Letter of Acceptance.
27. **The Intended Completion Date** is the date on which it is intended that the Contractor has to complete the Works. The Intended Completion Date is specified in the Contract Data. The Intended Completion Date may be revised only by the Superintending Engineer by issuing an extension of time.
28. **Materials** are all supplies, including consumables, used by the Contractor for incorporation in the Works.
29. **Plant** is any integral part of the Works that has to have a mechanical, electrical, chemical, or biological function.
30. **The Site** is the area defined as such in the Contract Data.
31. **Site Investigation Reports** are those that were included in the bidding documents and are factual and interpretative reports about the surface and subsurface conditions at the Site.
32. **Specification** means the Specification of the Works included in the Contract and any modification or addition made or approved by the Superintending Engineer.
33. **The Start Date** is given in the Contract Data. It is the latest date when the Contractor has to commence execution of the Works. It does not necessarily coincide with any of the Site Possession Dates.
34. **Subcontractor** is a person or corporate body who has a Contract with the Contractor to carry out a part of the work in the Contract, which includes work on the Site.
35. **Temporary Works** are works designed, constructed, installed, and removed by the Contractor that are needed for construction or installation of the Works.
36. **Two-cover system** means a procedure under which the bidders are required to simultaneously submit two separate sealed covers, one containing the Earnest Money (Bid security) and the details of their capability to undertake the tender which will be opened first and the second cover containing the price quotation which will be opened only if the bidder is found qualified to execute the Bid

PRELIMINARY SPECIFICATIONS FOR WORKS BELOW TWO CRORES

1. GENERAL

1.1 Definitions and Interpretations:

Wherever in these specifications or in any documents or instruments where those specifications govern the following terms or pronounce in place of them are used, the intent and meaning shall be interpreted as follows:

1-1-1. Corporation :

A statutory, body constituted under Chennai Act IV of 1919 as modified in 1936 and in 1961 having its office at the Ripon Buildings, Chennai.

1-1-2: Employer:

The Employer (Commissioner) or his authorised representative is the party who employs the Contractor to carry out the Works.

1-1-3 Commissioner:

The Commissioner is the executive authority for the purposes of carrying out the provisions of the Chennai City Municipal Act, who shall also perform all then duties and exercise all the powers specifically imposed or conferred on him

1-1-4 Superintending Engineer:

The Superintending Engineer who is, in-charge of the Department, Corporation of Chennai or his authorized representative limited by the particular duties entrusted to him.

1-1-5: Executive Engineer is an Executive Engineer of Corporation of Chennai and who is in charge of work in the Corporation of Chennai.

1-1-6 Tenderer or Bidder: Any person, firm or Corporation submitting a tender for the work contemplated, acting directly or through a duly authorized representative.

1-1-7: Contractor: The person, firm or Corporation undertaking the execution of the work under the terms of the contract, and acting directly or through a duly authorized representative.

1-1-8: Plans:

All official drawings or reproductions of drawing pertaining to the work provided for in the contract.

1-1-9. Specifications: The body of directions, provisions and requirements contained in these specifications, pertaining to the method and manner of performing the work and the quantities or quality of materials to be furnished under the contract.

1-1-10:Tender Notice:

The official notice inviting tender proposals for the work contemplated.

1-1-11:Tender Documents (or Tender Forms):The official document which is supplied to prospective bidders for preparing and submitting their tender and consisting of the tender notice, tender forms, schedule of approximate quantities, plans and specifications and the Descriptive specification sheet, Agreement etc.,

1-1-12. Contract: The written agreement covering the performance of the work of the proposed construction .The contract shall include the tender documents, tender proposals, articles of agreement, specifications, plans notice of handling over site, documents authorizing alterations and supplemental agreements.

1-1-13.Work: All performance required of the Contract or under the terms of the contract.

1-1-14.. Earnest Money :The security designated in the tender notice to be furnished by the bidder as a guarantee of good faith to enter into a contract for the work contemplated if it be awarded to him.

1-1-15.: Security Deposit: The approved form of security furnished by the contractor as a guarantee of good faith and ability on the part of the contractor to execute the work in accordance with the terms of contract.

1-2.Conditions

1-2-1: All documents bound with or attached to the tender forms shall be considered a part thereof and shall not be detached or altered.

1-2-2. 'Day' means a calendar day.

1-2-3 Party.

'Party' means either the Employer or the Contractor.

1-2-4. Cleaning up during Progress and for Delivery:

All rubbish shall be removed from the site as it accumulates. All works shall be leaned and put in a thoroughly complete, clean, sound and workmanlike state to the satisfaction of the Executive Engineer before the work is finally handed over, all surplus materials not required by Executive Engineer, having first been removed by the contractor. The contractor shall give notice in writing to the Superintending Engineer/Zonal Executive Engineer, when the work is so

ready to be handed over, and shall be responsible for its maintenance until it is taken over by the Superintending Engineer / Zonal Executive Engineer.

1-2-5. Interpretation of Estimates :

An estimate of quantities of work to be done or materials to be furnished under the specification is given in Schedule 'A'. These quantities are to be considered as approximate and are prepared for the comparison of bids only. The department does not expressly nor by implication agree that the actual quantities involved will correspond exactly therewith, nor shall the bidder plead misunderstanding or deception because of such estimate of quantities, or of the character, location or other conditions pertaining to the work. The unit prices to be tendered by the bidder are to be tendered expressly for the scheduled items of work and the quantities thereof may be increased or decreased in accordance with clause 1-2-7.

Payment to the contractor will be made for the actual quantities only of the work, performed or materials furnished in accordance with contract, and Tender Accepting Authority shall be ordinarily permitted to vary the quantity finally ordered only to the extent of 25 % either way of the requirement indicated in the tender documents. The payment will be made as per originally approved rate.

1-2-6 : Conformance :

The contractor shall perform all work in a substantial and acceptance manner in accordance with the plans and specifications and in accordance with such further explanatory drawing details and instructions as may from time to time be given by the Executive Engineer and above. If the work shown on any such further drawings or details, or other work necessary to comply with any such instructions, directions, or explanations, be in the opinion of the contractor, of a nature which the Schedule 'A' in contract does not legitimately cover, he shall before proceeding with such work give notice in writing to this effect to the Executive Engineer. In the event of the Superintending Engineer/Zonal executive Engineer and Contractor failing to agree as to whether or not there is any excess rate to be fixed and the Executive Engineer and above deciding that the contractor is to carry out the said work, the contractor shall accordingly, do so, and the question whether or not there is any excess, and if so the amount thereof being payable, failing agreement, be settled by an Arbitration as provided in the arbitration clause, unless the subject is one which is left to the sole discretion of the Executive Engineer and above under Clauses of these specifications and the contractor shall be paid accordingly.

It shall be responsibility of the contractor to give timely notice to the Executive Engineer and above, regarding anything shown on the drawings and not mentioned in the specifications, or mentioned in the specifications and not shown on the drawings, or any error or discrepancy in drawings or specifications and obtain his orders thereon. Figured dimensions are to be taken and not those obtained by scaling out. In any discrepancy between drawings and specifications the latter shall prevail. In any such case or in contractor shall forthwith apply to the Superintending Engineer/Zonal Executive Engineer for such further instructions, drawings or specifications as he requires, it being understood that the subject is to be dealt with under the building procedure of best modern practice. The Superintending Engineer/Zonal Executive Engineer will furnish the further instructions, drawings, or specifications, of in his opinion, they are required by competent workmen, for the proper execution of the work.

1-2-7.. RATES TO INCLUDE The tendered rates for items should be inclusive of all items of works required for the proper execution of the items (viz), watering, barricading lighting, watching, safety arrangements in the interest of traffic, etc., and no claim for extra payment on any score will be entertained. The rates to be tendered should be inclusive of sales tax and other taxes in force.

1-2-8. Examination of Plans, Specifications, Special Provisions and site of work

:Tenderers, must satisfy themselves by a personal examination of the site of the proposed work by examination of plans and specifications and by other means as they prefer as to the accuracy and sufficiency of the statement of quantities and all conditions affecting the work and shall not at any time after the submission of their tender, dispute or complain of such statement of quantities nor assist that apply for extension of time for completion beyond the agreement date.

1-2-9.. Approximate, not to mean Deviation from Drawings Specifications and Specifications :

The declaration of the approximate nature of the statement of quantities in Schedule 'A' does not, however in any way imply that the quantities will be increased for departure by the contractor from strict compliance with sanctioned drawings and specifications to suit, his own convenience or reduce his costs.

1-2-10. The Contract Unit Prices : The contract unit prices entered in schedule 'A' shall be for furnished work in situ or for articles or materials delivered at designated points and shall include

all contingent expenses whether direct or construction expenses or those imposed by an outside authority such as a import duties, tolls, octroi, seigniorage sales tax, quarry fees, etc. The Contractor shall be solely responsible for the payment of sales tax under the provisions of the Chennai General Sales Tax Act, 1939 (Chennai Act IX of 1939) as on force for the time being and rates for the various items of work shall remain unaffected by any charge that may be made from time to time in the rate at which such tax is payable. Further the contractor is liable to pay Sales Tax (as applicable to works contract) etc., for this work to the commercial tax department as and when claimed.

1-2-11. Carriage : Rates for finished work shall always include the cost of conveyance and all leads lifts, loading unloading and stacking in a manner and at the place ordered by the Superintending Engineer. When materials are supplied by department, the place of supply will be specified in the specifications and no extra payment will be made for conveyance, lead, lifts, loading, unloading or stacking etc. Wherever the term "Carriage" or "Conveyance" is used it shall be taken to include all leads, lifts, loading, unloading and strong to the satisfaction of the Superintending Engineer /Zonal Executive Engineer.

1-2-12. Construction Plant :The Contractor shall include in his tendered price, and shall provide and install necessary construction plant and shall use such methods and appliances for the performance of all the operations connected with the work embraced under the contract as will secure a satisfactory quality of work and rate of progress which will ensure the completion of the work within the time specified. If at any time before the commencement, or during the progress of work or any part of it, such methods of appliances appear to the Superintending Engineer/Zonal Executive Engineer to be insufficient or inappropriate for securing the quality of the work required, or the said rate of progress, he may order the contractor to increase their efficiency, or to improve their character and the contractor shall comply with such orders; but the failure of the S.E/ Zonal Executive Engineer to demand such increase of efficiency or improvement shall not relieve the contractor from his obligation to secure the quality of work and the rate of progress required by the contract and the contractor alone shall be responsible for the efficiency and safety of this plant, appliances and methods. All requisite staging, shutting, etc. be provided at the contractor's expense in sufficient quantity proper quality to ensure progress in conformity with the contract.

1-2-13. Temporary Structures :

The contractor shall erect and maintain at his own cost temporary weather proof sheds at such places and in manner approved by the Superintending Engineer/Zonal Executive Engineer for keeping materials under cover. The contract shall also provide and maintain his own expenses such temporary fences, guards, etc., as may be necessary for the execution of his contract work or for safe guarding or accommodating the public. If the Superintending Engineer/Zonal Executive Engineer shall order any departure form any arrangements made by the contractor and the contractor shall comply with such orders as the Superintending Engineer/Zonal Executive Engineer may issue to safeguard or accommodate the public.

The Contractor shall remove the Temporary Structure before handing over of the site after completion of the work and if the same is not done, the Executive Engineer of the respective work shall have the right to remove such temporary structure and the contractor cannot claim for any damage or loss of materials.

1-2-14. Water and Lighting :

The contractor shall pay for all fees and provide water and light as required from M.M.W.S.S. Board mains or other sources, and as shall pay all charges therefore the use of the works and workmen. The Water for the works shall be free from earthy, vegetables or organic matter, and from salts or other substances likely to interfere with the setting of mortar or otherwise prove harmful to the work.

1-2-15. Latrines for work People :

The contractor shall provide and erect, prior to the commencement of work, sufficient latrines for the use of work people, male and female, and shall keep the same disinfected and clean at all times during the progress of the works and shall remove the same, disinfect the ground and make good all damages on the completion of the works.

1-2-16. Sun Protection, and removal of rain water. :

The contractor shall at his own expense arrange all requisite protection of the work and materials against sun and rain effects and pumping of excess water to the satisfaction of the Superintending Engineer /Zonal Executive Engineer for the purpose at his expenses.

1-2-17. Setting out of Works :

The contractor shall be responsible for the current setting out of all works, providing at his own cost all labour, materials and staff required for so doing.

1-3 PLANS AND SPECIFICATIONS

1-3-1 Intent of the Plans and Specifications :

The contractor drawings together with the contract, specifications, are intended to show and explain the manner of executing the work and to indicate the type and class of materials to be used.

1-3-2 Increased or decreased Quantities :

Supplemental Agreement will be required in case the total value exceeds by 25 %.

The right is reserved at any time during which the contract is in force, to make such alterations in the plans on the quantities of work as may be necessary including the extension or shortening of the length of the project. Such alterations shall, in so far as practical, be ordered in writing before standing work on such alterations, and no sign drawings shall be taken as in itself as order for variation unless accompanied by a covering letter from the Superintending Engineer confirming that the drawings is an authority for variation further, the quantities of any items of work may vary from the quantities in Schedule 'A' due to unforeseen or other conditions.

Supplemental Agreements will be required in case the total contract value exceed by 25%

The contractor shall not start work on any alterations requiring a supplemental agreement until the agreement setting forth an equitable adjustment of compensation, satisfactory to both the parties, shall have been executed.

The contractor shall perform the work as increased or decreased Payment to the contractor will be made for the actual quantities only of the work, performed or materials furnished accordance with the contract, and Tender Accepting Authority shall be ordinarily permitted to vary the quantity finally ordered only to the extent of 25 % either way of requirement indicated in the tender documents. The payment will be made as per originally approved rate

1-3-3 Copies of Drawings and Specifications :

Two copies of the available drawings and specifications shall be furnished free of cost of the contractor for his own use. Such copies and copies of Supplementary details furnished by the Superintending Engineer shall be kept on the work until the completion and the Superintending Engineer/ Zonal Executive Engineer shall at all times have access to them.

1-3-4 Omitted Items :

The right reserved to cancel the portion of the contract relating to any items or portions thereof in any stage of execution it found unnecessary to the work and such omission shall not be a waiver of any condition of the contractor or invalidate any of the provisions thereof.

1-3-5 Non –Tendered Items.

In connection with the work covered by the Contract the Superintending Engineer/Zonal Executive Engineer may, at any time during its progress, order for other works or materials incidental thereto. All such work and materials as do not appear in the proposal or contract as a specific item accompanied by unit price and which are not include under the price bid for other item in the contract shall be designated as Extra work.

Extra work may also consist of additions to or charges in design in contract items or portions thereof when such additions are wholly disassociated form or outside the scope of the work of evidence by the plans, special provision and specifications and when the work caused by such additions or charges in design must be performed under conditioned or in a manner that is materially and inherently different from the conditions and manner existent for such contract items as contemplated in original scope of the work.

The contractor hereby agrees to and he shall perform extra work whenever it is deemed necessary or desirable by the Superintending Engineer / Zonal Executive Engineer to complete fully the work as contemplated, and it shall be done in accordance with the requirements herein set forth. The contractor shall not perform any extra works until a Supplemental Agreement setting forth a basis of payment satisfactory to both parties as herein after provided, has been executed, claims for compensation for extra works performed which ash not been authorized and not covered by Supplemental Agreement may be rejected.

The Supplemental Agreement for extra work may provide for payment on an agreed unit price basis for the units of such extra work performed in and agreed lumpsum for the work described, or on the basis of actual in conformity with clause.

1-3-6.Extra Work. If Extra work is to be performed on the basis of actual the Supplemental Agreement shall specify the agreed rates of wages and allowances to be paid for foreman, labour and terms, and the agreed rental rate to be paid for each piece of equipment other than

small tools, which rental rate shall include fuel, lubricants, moving, and other costs incidental to the use of such equipment.

1-4 MATERIALS AND WORKMANSHIP

1-4-1 Quality of Materials : It is the intent of these specifications that first class materials shall be used throughout the work, and that they shall be incorporated in such a manner as to produce completed construction which is workmanlike and acceptable to Assistant Executive Engineer in every detail. Only materials which conform to the requirements of these specifications shall be furnished or incorporated in the work. The contractor shall upon the request of the Assistant Executive Engineer, furnish him with the vouchers to prove that the materials are such as specified. Samples of materials with test certificates have to be furnished at the contractor's expenses for the approval of the Assistant Executive Engineer prior to the execution of any work.

1-4-2. Corporation Furnished Materials :

The contractor shall furnish all materials required to complete the work, except such materials as are designated to be furnished by the department. Upon written request of the contractor such materials will be delivered to him with a reasonable time at the points designated in the contract. They shall be unload and hauled to the site for the work by the contractor at his expense. The cost of handling and placing all materials after they are delivered to the contractor shall be considered as included in the contract unit prices for the items in connection with they are used.

The contractor shall be responsible for all materials delivered to him, and shall use them only for the purpose of the contract. Deductions will be made from any amount due to him to make good any damage storage or decency, from any cause whatsoever which may occur after such delivery or for any demurrage charges sue to delinquency in unloading.

If the materials are furnished by the department the Corporation shall have a lien upon the surplus quantities of each materials and the contractor shall deliver them as directed by the Superintending Engineer and at the contractor's expenses.

1-4-3. Tests :

All test of materials furnished by the contractor shall be done in accordance with commonly recognized methods of Indian or of other National Organization or such other methods and test as are prescribed in the specifications or are in use of conformity with the standard practices of the department and the charge there for will be borne by the Department, beyond the prescribed test.

Field test of materials will be made by the Asst. Executive Engineer when deemed necessary and these tests shall be made in accordance with the standard practice. The cost of labour involved in all such field tests will be borne by the contractor.

The contractor shall upon demand, forward for the Superintending Engineer's/Zonal Executive Engineer's inspection test certificates by the suppliers for all materials furnished by the contractor.

1-4-4. Inspection of Materials :

The contractor shall provide proper facilities at all times for the inspection and testing of materials, and the Executive Engineer shall have access at all times to the place of storage or manufacture. The contractor shall give sufficient advance notice of placing orders so as to permit tests to be completed before the materials are incorporated in the work and he shall afford such facilities as the Executive Engineer may require for collecting and forwarding samples and making inspection. The contractor shall not make use of or incorporate in the work the materials represented by the samples until tests have been made and the materials found to be in accordance with the requirements of the specifications.

All stored materials shall be inspected at the time of use in the work even though they may have been inspected and approved before being place din storage or during storage.

Materials may be inspected and tested at any time during the progress of the work and defective materials rejected.

1-4-5. Defective Materials :

All materials not conforming to the requirements of these specifications shall be considered as defective and all such materials, whether in place or not shall be rejected. They shall be removed immediately by the contractor at his expense and replaced with acceptable material. No rejected material, the defects of which have been subsequently corrected, shall be used on the work until approved in writing has been given by the Superintending Engineer/ Zonal Executive Engineer. Upon failure on the part of the contractor to comply with any order of the Superintending Engineer/ Zonal Executive Engineer made under the provisions of this article within the time stipulated by the Superintending Engineer/Zonal Executive Engineer , the

Superintending Engineer/ Zonal Executive Engineer shall have authority to remove and replace the defective material and recover the cost of removal and replacement from the contractor. Further, all such defective material lying at site not removed and replaced within 30 days after issue of notice by the Superintending Engineer/Zonal Executive Engineer. If the Superintending Engineer / Zonal Executive Engineer so decides, shall become the property of the Corporation and the Superintending Engineer shall dispose of such material in any manner without any further written notice to the Contract.

1-4-6. Storage of Materials :

The contractor shall deposit materials in such parts only at the ground as may be approved by the Superintending Engineer/Zonal Executive Engineer. He shall submit for the approval of the Asst. Executive Engineer before starting the work, a detailed site survey clearly indicating the locations where materials shall be stored and sheds built. Such of the land, as is vested in the Corporation around the site, shall be given to the contractor. If any extra space is required the contractor should make his own arrangement with private parties. Storage sites be vacated immediately upon completion cleared of all surplus materials and debris and restored as neatly as possible to their original condition by the contractor at his expense.

Materials shall be stored as to insure the preservation of their quality and fitness for the work. When considered necessary by the Superintending Engineer/ Zonal Executive Engineer they shall be placed on wooden platforms or other hard, clean surfaces and not on the ground. They shall be placed under cover when so directed and the contractor shall erect and maintain at his own cost temporary weatherproof sheds for the purpose. Stored materials shall be so located as to facilitate prompt inspection.

1-4-7.Measurement and Mixing : In the case of loose materials such as sand, broken stone, mortar, etc. the proportions demanded by the specifications must be measured in properly constructed measuring boxes, or in such other manner as shall be instructed by the Superintending Engineer/Zonal Executive Engineer. Measurement is not to be done in loose heaps when intimate mixtures such as mortar, concrete etc. are to be formed. The mixing must always be done on closely constructed platforms so that there will no leakage of any of the materials through the floor of the platform and also so that no foreign materials can be incorporated during mixing. These platforms must be approved by the Superintending Engineer/ Zonal Executive Engineer. The cost of such measuring boxes and platforms and all the work referred to here in shall be borne by the contractor.

1-4-8. Authority of Superintending Engineer / Zonal Executive Engineer:

All works shall be done under supervision of the Superintending Engineer/ Zonal Executive Engineer and to his satisfaction. He shall decide all questions which arise as the quality and acceptability of materials furnished, work performed, manner of performance, and rate of progress of the work, interpretation of plant and specifications, and acceptance of fulfillment of the contract. He shall determine the amount and quality of work performed and materials furnished and his decision and measurement shall be final. In all such matters and in any technical question which may arise touching the contract, the Superintending Engineer's/Zonal Executive Engineer's decision shall be final and binding in the contractor. The Superintending Engineer/Zonal Executive Engineer shall have power to enforce such decision and orders of the contractor fail to carry them out promptly. In case of failure on the part of the contractor to execute work ordered by the Superintending Engineer/Zonal Executive Engineer. The Superintending Engineer / Zonal Executive Engineer may give notice in writing to the contractor, and at the expiration of the reasonable period specified in the notice proceed to execute such work as may be deemed necessary and the cost thereof shall be recovered from the contractor. If any disputes arises, the decision of the Superintending Engineer/Zonal Executive Engineer , in all aspects will be binding

1-4-9. Departmental Representative :

The Executive Engineer during his absence of the work shall be represented by one of his subordinates whose duties in relation to the contractor shall be confined to ensuring that the work is performed in conformity with the plans and specifications in all respects. He shall communicate to the contractor the instructions and directions of the Executive Engineer on all questions relating to the work and the contract or shall comply with such instructions and directions.

He shall direct the contractor in writing to suspend the performance of any part of the work if, in his judgment the contractor is deviating from the plans and specifications in spite of his constructions and the contractor shall comply.

1-4-10.Co-operation by Contractor:

The contractor shall give the work his constant attention to facilitate the progress thereof, and shall co-operate with the department in every way possible. He shall have on the work at all times a competent representative who can speak the local language, authorized to receive orders and act for him. The contractor shall provide all staff that is necessary for proper setting out, supervision, execution and measurement of work in full compliance with the contract. Persons employed to supervise the work shall have adequate qualifications and experience of similar works and shall be able to supervise the work to the satisfaction of the Superintending Engineer/ Zonal Executive Engineer .The contractor shall, on request from the Superintending Engineer/Zonal Executive Engineer promptly cease to employ in connection with the contract and replace any person whose continued employment in connection therewith is in the opinion of the Superintending Engineer undesirable. He shall not be re-employed in connection with the contract without the written permission of the Superintending Engineer/ Zonal Executive Engineer. The decision of the Superintending Engineer/Zonal Executive Engineer is final upon any matter arising under this condition .The decision communicated in writing should be promptly complied forthwith by the contractor. Any violation will attract penal action.

1-4-11. Detailed Setting Out :

The contractor shall be responsible for the correct time and proper setting out of the work and for the correctness of the positions, levels, dimensions and alignments of all parts of the works and for the provisions of all necessary instruments, appliances and labour in connection therewith. If at any time during the progress of the works any error shall appear or arise in the position, levels, dimensions or alignment of any part of the works the contractor on being required to do so by the Executive Engineer shall at his own expenses, rectify such error to the satisfaction of the Executive Engineer. The checking of any setting out by the Executive Engineer shall not in any way relieve the contractor of his responsibility for the correctness thereof and the contractor shall carefully protect and preserve and bench marks, constructions stake and other things used in setting out the work.

1-4-12. Inspection and Works :

All materials and each part or detail of the work shall be subject at all times to inspection by the Superintending Engineer/ Zonal Executive Engineer and the contractor will be held strictly to the true intent of the specifications in regard to the quality of materials, workmanship and the diligent execution of the contract. The Superintending Engineer/ Zonal Executive Engineer shall be allowed access at all times to all parts of the work and to places of storage or manufacture, and shall be furnished with such information and assistance by the contractor as required to make a complete and detailed inspection.

1-4-13.Uncovering for Inspection :

No additional compensation shall be made for removing, uncovering and replacing any portion of the work in connection with routine inspection. The contractor shall, if the Superintending Engineer /Zonal Executive Engineer request remove or uncover such portions of the finished work as the Superintending Engineer/Zonal Executive Engineer may direct before the final acceptance of the same. After such special examination, the contractor shall restore them to the standard required by the specifications. If no instructions of the Superintending Engineer/Zonal Executive Engineer were contravened in covering up the work, and if the work on being exposed and examined proves acceptable, the cost of uncovering and of restoration shall be paid as extra work but if the work proves unacceptable, the cost shall be borne by the contractor.

If the contractor fails to uncover or having uncovered fails to restore within the time stipulated by the Superintending Engineer /Zonal Executive Engineer , he may employ other workmen for these operations, and debit the contractor with the cost of uncovering and restoration if the work proves unacceptable.

1-4-14. Removal of defective and unauthorized work :

The Executive Engineer may reject at any stage before final acceptance of any work that he considers to be not in conformity with the plans and specifications, or any extra works done without authority and such work will not be measured and paid for.

All work which has been rejected shall be remedied or removed and replaced promptly in an acceptance manner by the contractor at his own expense. Upon failure on the part of the contractor to comply with any order of the Executive Engineer under the provisions of these articles a written notice shall be issued by the Executive Engineer to the Contractor, demanding compliance with a stipulated time. If the contractor continues to default till the expiry of the period of notice the Executive Engineer shall have authority to cause defective work to be

remedied, or removed and replaced, or to cause unauthorized, or to cause unauthorized work to be removed, and to recover the cost thereof from the contractor.

In lieu of rejecting work done or materials furnished not in conformity with the contract, the Executive Engineer may allow such work or materials to remain, provided the Superintending Engineer/ Zonal Executive Engineer is satisfied with the quality of the materials or the strength and structural safety of the work, and in that case shall make such deductions for the difference in value as in his opinion may be reasonable on the written certificate of the Executive Engineer.

1-4-15. Penalty for poor quality of work :

Notwithstanding the provisions as contained in clause 1-4-14, the contractor is also liable for a penalty of 5% of the value of the poor quality of work done which is rejected by the Executive Engineer which penalty will be deducted from any amount to the contractor by the Corporation of Chennai. The contractor will be required to remit the amount in the Corporation treasury immediately before proceeding with further work as per directions of the Executive Engineer, and remove substandard work/defective work.

1-5. RESPONSIBILITIES AND LAIBILITIES OF THE CONTRACTOR

1-5-1 Laws to be observed :

The contractor shall at all times observe and comply with all Union and State laws, local laws, ordinances and regulations which in any manner affect the conduct of the works and all such orders as exist at the present and which may be enacted in the future by legislative bodies or tribunals having legal jurisdiction or authority over the work and no plea of misunderstanding or ignorance thereof will be considered. He shall indemnify and save from harm the Corporation and all its officers, agents, employees and servants against and claim or liability arising from or based on the variation of any such law, ordinance, regulation, order or decree whether by himself or by his employees. He shall also assure that no attachments are made against materials on works forming part of or for the use of the contract.

All scaffolding runways, hosts and other temporary construction shall comply with all pertinent requirements of Union and State laws, local law ordinances and regulations.

1-5-2 Public Safety :

This article defines the contractor's responsibility with regard to providing for the safety of the public during constructions.

The contractor shall furnish, erect and maintain such fences, barricades, and signs as are necessary to give adequate warning to the public at that construction is under progress and of any dangerous conditions to be encountered as a result there of in accordance with any departmental type designs or as directed by the Executive Engineer.

At any and all points along the work where the nature of construction operations in progress and the contractor's equipment and machinery in use is of such character as to endanger passing traffic the contractor shall provide such lights and signs and station such guards as may appear necessary to prevent accidents and avoid damage or injury to passing traffic.

No material or equipment shall be stored where it will interfere with the free and safe passage of traffic. At the end of each day's work and other items when construction operations are suspended for any reasons, the contractor shall remove all equipment and other obstruction from that portion of the road open for use by traffic.

Full compensation for the work involved in carrying out the precautionary and safety measure above specified shall be considered as included in the prices paid for the various contract items of work and no additional allowance will be made there for.

1-5-3. Accidents :

It shall be the contractor's sole responsibility to protect the public and his employees against accident from any cause and he shall indemnify the Corporation against any claims for damages for injury to person or property, resulting from any such accidents, and shall, where the provisions of the Workmen's Compensation Act apply, take steps to property insure against any claims there under.

The contractor shall take out the insurance against any accidents at work site as mentioned above before the commencement of the work and produce the insurance policy before the payment of first part bill.

Within 24 hours of the occurrence of an accident which results in the death or which is so serious as in all probability to result in the death of may workman employed by the contractor, he shall intimate in writing to the Superintending Engineer/ Zonal Executive Engineer the fact of such accident. The contractor shall indemnify the Corporation against all loss or damage sustained by it resulting directly or indirectly from his failure to give intimation in the manner aforesaid including the penalties of or fines if any payable by the Corporation as a consequence of its failure to give notice under the Workmen's Compensation Act or other wise conform to the provisions of the said Act in regard to such accident.

1-5-4.Scaffoldings: Suitable scaffolds should be provided for workmen for all works that cannot safely be done from the ground, or from solid construction except such short period work as can be done safely from ladder. When a ladder is used an extra mazdoor shall be engaged for holding the ladder and if the ladder issued for carrying materials as well, suitable footholds and hand holds shall be provided on the ladder and the ladder shall be given an inclination not steeper than $\frac{1}{4}$ to 1 (1/4 horizontal and 1 vertical)

Scaffolding or staging more than 3.6m (12 feet) above the ground or floor, swung or suspended from an overhead support or erected with stationary support shall have guard rail properly attached, or bolted, braced and otherwise secured at least 90 cm (3 feet) high above the floor or platform of such scaffolding or staging and extending along the entire length of the outside and ends thereof with only such opening as may be necessary for the delivery of materials. Safe means of access shall be provided to all working platforms and other working places.

Every ladder shall be securely fixed. No portable single ladder shall be over 9 m (30 feet) in length while the width between side rails in rung ladder shall in no case be less than 28 cm (11 $\frac{1}{2}$ ") for ladder up to and including 3 cm (10 feet) in length. For longer ladder this width should be increased at least $\frac{1}{4}$ " for each exceed 30 cm (12"). Adequate precautions shall be taken to prevent danger from electrical equipment. No materials on any of the sites of work shall be so stacked or placed as to cause danger or inconvenience to any person or the public. The contractor shall provide all necessary fencing and lights to protect the public from accident and shall be bound to bear the expenses of defence of every suit, action or other proceedings at law that may be brought by any person for injury sustained owing to neglect of the above precautions and to pay any damages and cost which may be awarded in any such suit,action or proceedings to any such person or which may with the consent of the contractor, be paid to compromise and claim by any such person.

Working platforms and gangways should be so constructed that they should not sag unduly or unequally, and if the height of the platform or the gangway or the stairway is more than 3.6 m (12 feet) above the ground level or floor level, they should be so closely boarded, should have adequate width and should as suitable fastened as described in 1-5-4 above.

Every opening in the floor of a building or in a working platform should be provided with suitable means to prevent the fall of persons or materials by providing suitable fencing or railing whose minimum height shall be 90 cm (3 feet).

Safe means of access shall be provided to all working platforms and other working places. Every ladder shall be securely fixed. No portable single ladder shall be over 9 m (30 feet) in length while the width between side rails in rung ladder shall in no case be less than 28 cm (11 $\frac{1}{2}$:") for ladder up to and including 3 cm (10 feet) in length. For longer ladder this width should be increased at least $\frac{1}{4}$ " for each exceed 30 cm (12"). Adequate precautions shall be taken to prevent danger from electrical equipment. No materials on any of the sites of work shall be so stacked or placed as to cause danger or inconvenience to any person or the public. The contractor shall provide all necessary fencing and lights to protect the public from accident and shall be bound to bear the expenses of defense of every suit, action or other proceedings at law that may be brought by any person for injury sustained owing to neglect of the above precautions and to pay any damages and cost which may be awarded in any such suit, action or proceedings to any such person or which may with the consent of the contractor, be paid to compromise and claim by any such person.

1-5-5.Insurance: Group insurance policy should be kept alive at the time of issue of work order If Insurance is not taken by the tenderer it will be deducted from the bill or EMD will be forfeited. Contractor shall have to provide All Risks Insurance Policy which provides complete protection against all types of civil construction risks. The Comprehensive insurance policy should provide complete protection against all types of construction works. All risks policy should cover against a wide range of perils such as Fire, Lightning, Explosion, Aircraft Damage, Riot, Strike, Flood, Inundation, storm cyclone, Land slides, Burglary, Human Errors, Short-circuiting, Collapses Etc. The policy should cover the legal liability falling on the insured contractor as a result of bodily injury or property damage suffered by a Third Party .All payments received from Insurers relating to loss or damage to the works shall be held jointly by the parties and used for the repair of the loss or damage or as compensation for loss or damage that is not to be repaired.

1-5-6. Remedy to Contractor's failure to insure.

If the Contractor fail to effect and keep in force the insurances referred to or any other insurance which he may be required to effect under the terms of the contract ,then and in any such case the Department may effect and keep in force any such insurance and pay such premium as may be necessary for the purpose and from time to time deduct the amount so paid by the Department as afore said from any moneys due or which may become due to the contractor or recover the same as a debt due from the Contractor

1-5-7.Responsibility for Damage claims:

The contractor shall indemnify and save from harm the Corporation, its officer and employees from all suits actions or claims of any character brought because of any injuries or damages received or sustained by any person, persons or property on account of the operations of the said contractor of an account or in consequence of any neglect in safeguarding the work, or through use of unacceptable materials in constructing the work or because of any claims or accounts recovered for any infringement of patent, trade mark or copy right, or from any claims or amounts arising or recovered under the Workmen's Compensation Act, or any other law, ordinance, order or decree; and so much of the money due to the Contractor under and by virtue of his contract as shall be considered necessary by the Superintending Engineer for such purposes may be retained for the use of the Corporation. The Corporation shall not be liable to the contractor for damages or delays resulting from work by third parties or by injunctions or other restraining orders obtained by the third parties.

1-5-8.Protection and Restoration of Property:

If corporate or private property interferes with the work the contractor shall notify in writing the owners of such property advising them of the nature of the interference and shall arrange with them for the disposition of such property. The contractor shall furnish the Superintending Engineer with copies of such notified and final agreements.

The contractor shall use every precaution to prevent the damage or destruction of corporate or private property including building, etc. He shall protect or carefully preserve or all official survey monuments, bench marks, boundary stones, etc., until the owner or an unauthorized agent has witnessed or otherwise referenced their location or relocation. The contractor shall notify the Superintending Engineer of the presence of any such surveyor property monuments as soon as they are discovered. The contractor shall be responsible for the damage or destruction of property of any character resulting from any of his acts or defaults or from defective work or materials, and such responsibility shall not be released until the work is completed and accepted. Whenever public or private property is damaged or destroyed the Contractor shall at his own expenses restore such property to a condition similar to or equal to that existing before such damage or injury in the acceptable manner.

If he fails to do so, the Superintending Engineer/Zonal Executive Engineer may, , after the expiration of a period of 48 hours, after giving notice to him in writing, proceed to repair, build or otherwise restore such property as may be deemed necessary and the cost thereof shall be recovered form the contractor.

1-5-9. Contractor's Risk and Insurance:

The work executed by the contractor under the contractor shall be maintained at the Contractor's Risk until the work is taken by the Superintending Engineer. The contractor shall accordingly arrange his own insurance against fire and other loss or damage occasioned by or arising out of acts of God in particular unprecedented flood, volcanic eruptions, earthquake or other convulsion of Nature, invasion, the act of foreign enemies, hostilities or war like operations (before and after declaration of war), rebellion Military or unswaped power of civil war

1-5-10. Night and Holiday work Prohibited without permission :

No work shall be done on holidays or during nights without the written permission of the Superintending Engineer / Zonal Executive Engineer and the Contractors shall comply with the provision of the Factories Act, if and so far as they are applicable.

The Contractor shall give prior information to the Police Department, if necessary, for carrying out the work during night hours.

1-6. Execution of work and progress

1-6-1 Sub-letting or Assignment Contract :

The contractor shall not assign, transfer, convey, sell or otherwise dispose of the whole or any part of his contract, his right title, or interest therein, or his power to execute such contract, to any person, firm partnership of Corporation without written consent of the Commissioner.

If the contractor sub-lets the whole or any part of the work to be done under this contract he shall not under any circumstances be relieved of his liabilities and obligations. All transactions of the Superintending Engineer/Zonal Executive Engineer shall be with the contractor; sub-

contractors shall be recognized only in the capacity of employees or workmen and shall be subject to the same requirements as to character and competence.

1-6-2 Commencement of Work:

Within 7 days from the date of handing over of site or issue of work order which ever is later the contractor shall begin the work. He shall begin the work duly notifying the Superintending Engineer / Zonal Executive Engineer the date of such commencement. The contract time shall start the date on which the contractor shall start construction operations as preparatory works and in any event within 10 days from the date on which the above notice is served to the contractor. The contractor under no circumstances will be entitled to claim any damage from the Corporation if he incurs any expense or liabilities under the contract before the date of commencement, defined above. He shall have the right to withdraw from the contract or obtain any refund of the earnest money and security deposit if intimation of handing over the site is delayed for more than a period of ninety days from the date of issue of work order by the competent authority.

1-6.3. Commencement & Completion of work.

Prior to commencement of work, the Engineer and the Contractor shall carryout a joint inspection of the existing surface to locate any areas where defective foundations or improperly consolidated trenches may have contributed to surface failure. During the progress of the work further checks on the adequacy of the foundation by means of trial holes, plate bearing tests, etc., shall be made any defects noted shall be pointed out to the Executive Engineer who will issue instructions for the necessary remedial action to be ensured that a satisfactory foundation is available through the area to be resurfaces. When the asphaltic concrete is to be laid at the bus stop, the flow shall not exceed 12. For bitumen the work ordered to be carried out shall be commenced within three days from the date of acceptance of the tender and complete within the stipulated time to the satisfactory of the Executive Engineer or his representatives. If the rate of progress is poor as judged by the Executive Engineer or his authorized representative a fine not exceeding Rs 0.05 %-of work value per day shall be imposed on the Contractor

1-6-4 Suspension of Work:

The Superintending Engineer/ Zonal Executive Engineer shall have authority to suspend the work, wholly or in part, for such period of times as he may deem necessary due to unsuitable weather or such other conditions as are considered unfavorable for the satisfactory execution of the work, or for such time as is necessary by reason of failure on the part of the contractor to carry out orders given, or to perform any or all provisions of the contract and no additional compensation shall be paid to the contractor because of such suspension in the even of such suspension of work the contractor shall store all materials in such manner that they will not obstruct or impede the traveling public unnecessarily or become damaged in anyway, and he shall take every precaution to prevent damages or deterioration of the work performed, provide suitable drainage of the roadway, and temporary structures where necessary. The contractor shall not suspend work without written authority.

1-6-5 Delay and Extension of Contract Time of Completion:

The time for completion of the work contemplated will be specified in the proposal and contract and it is understood that the completion of the work the time specified is an essential part of this contract. If any delay in the completion of the work is alleged to be or likely to be caused by reason of any of the following circumstances.

- a) The execution of any modification in additional work.
- b) Delay caused by any written instructions issued by the Superintending Engineer
- c) Any act or default of the Superintending Engineer/ Zonal Executive Engineer including failure to issue necessary instructions upon written request from the contractor.
- (d) Any of the accepted risks under Clause 1-5-6
- (e) Any circumstances which are wholly beyond the control of the contractor and unavoidable.

The contractor shall upon the occurrence of the alleged cause of delay, give notice thereof in written to the Superintending Engineer /Zonal Executive Engineer within fourteen days of the commencement of the delay and he shall be allowed a reasonable extension of time for completion in respect of any delays caused by any of the above mentioned circumstances. The Superintending Engineer /Zonal Executive Engineer shall assess the period of delay, at twenty five percent in excess of the actual working period so last and extend the time of completion of the contract. In assessing any extension of time, account shall be taken of the effect of the omission of any work. Any further extension of time under the provisions herein before contained may be allowed notwithstanding that the contractor has failed to give notice of the cause therefore or that the date for completion may have passed or that the work may have been completed.

1-6-6.: Determination of Contract due to default or failure of the Contractor.

The commissioner may without prejudice to the rights of the Corporation against the contractor in respect of any delay or inferior workmanship or otherwise, or any claims for damage in respect of any breaches of the contract and whether the date for completion has or has not elapsed by notice in writing absolutely determine the contract in any of the following cases:-

(a) If the contractor, having been given by the Superintending Engineer/ Zonal Executive Engineer a notice in writing to rectify, reconstruct or replace any defective work or a notice in writing that the work is being performed in an inefficient or otherwise improper manner or that the commencement of the work is being delayed or has been suspended so that in Judgment of the Superintending Engineer/ Zonal Executive Engineer the contractor will be unable to secure the completion of the work by that date shall omit to comply with the requirements of such notice for a period of seven days thereafter. Such notice under the provisions of this Article and must specify the act or default on the part of the contractor upon which it is based.

(b) (i) If the contractor being an individual or where the contractor is a firm or any partner in that firm shall, at any time become bankrupt, or shall have a receiving order made against him or shall make any composition or arrangement with or for the benefit of his creditors or shall make any conveyance or assignment for the benefit of his creditors, or shall purport to do so; or

(ii) If the contractor, being a company, shall pass a resolution, or the Court shall make an order that the company be wound up, or if receiver or manager on behalf of creditor shall be appointed or if circumstances shall arise which entitle the Court or a creditor shall be appointed or if circumstances shall arise which entitle the court or a creditor to appoint a receiver or manager entitle the court to make a winding up order.

(c) If the contractor dies, becomes insane or is imprisoned, provided always that such determination shall not prejudice or affect any right of action or remedy which shall have accrued or accrue thereafter to the Corporation. Provided further, that after the notice under condition 165-a, herein shall have been served on the contractor he shall not be at liberty to remove from the site of the work or from adjoining ground any plant materials and equipment belonging to him and placed thereon for the purpose of the work and the Corporation shall have a lien upon all such items subsisting from the date of such notice until the notice shall have been complied with. The Superintending Engineer shall have power to post watchman at the site of the work and / or the ground continuous there to prevent the removal of any plant, materials and equipment upon which the Corporation shall a lien.

1-6-7. Forfeiture and Partial Determination:

Notwithstanding the failure of the contractor to comply with notice served on him under clause 1-6-5(a) herein, the Superintending Engineer/ Zonal Executive Engineer may in his discretion permit the contractor to proceed with the work in conformity with the contract. Such permission shall carry with it the forfeiture of the sum of money not exceeding 5 percent of the total of the finished contract amount provided however that his forfeiture may be modified or revoked by Commissioner.

It shall be further right of the Commissioner under this para, to determine any part of the contract and to proceed with the execution of the relative portion of the work through any other agency in order to maintain the rate of progress stipulated in the contract. Such omission shall not be a waiver of any condition of the contract nor invalidate any of the provisions thereof. The contract shall diligently proceed with the portions of the work left to him and payment of money due or may become due shall only be made after deducting there from the extra cost as ascertained by the Superintending Engineer/ Zonal Executive Engineer that may be involved in executing parts of the work through other agency. The decision of the Commissioner in this respect shall be final and conclusive.

1-6-8 -Provisions in case of Absolute Determination of Contract :

If the Commissioner shall in the exercise of the powers contained in Clause 1-6-7 and the value of such as may have been executed but not paid for and all other sums of money that may then be due or becoming due from the department to the contractor shall cease to be due or become due.

(a) The earnest money, the security deposit, the total amount withheld under clause 1-6-7 and the value of such work as may have been executed but not paid for and all other sums of money that may then be due or becoming due from the department to the contractor shall cease to be due or become due.

(b) The Commissioner may enter upon and take possession of site and of the materials, tools, plant and equipment thereon, and may purchase materials and do all other acts requisite, for the completion of the work. He may employ other contractors to complete the same, and the contractor shall have no claim whatsoever in respect of such action by the Commissioner. The

Commissioner has the authority to for taking steps for debarring the contractor in the future participation of Tenders or any dealing with Corporation Of Chennai.

(c) The contractor shall, if required by Commissioner assign to the Corporation without further payment, the benefit of any sub-contract or sub-contracts he may have made in connection with the contract and the Corporation shall pay to such person or persons the price (or the balance thereof remaining unpaid), which the contractor may have agreed to pay there under.

(d) Upon completion of the work Superintending Engineer/ Zonal Executive Engineer shall certify the cost of completion, which shall include:

(i) The cost of any materials purchased and labour provided to secure completion work, including the making good of any defects and faulty work, together with the addition of such percentage to cover supervision and establishment charges as may be decided by the Superintending Engineer.

(ii) The cost of work, executed by other contractors to secure completion of the work, including the making good of any defects and faulty work.

(iii) The cost of maintenance of the portion of the work completed by the contractor.

(2) If the cost of completion, after taking into account all credits from any sales of materials, plant and equipment brought on the site by the contractor prior to the date of determination, added to the actual sums paid to the contractor upto the date is less than sums which would have been payable to the contractor for due completion, the contractor shall be paid the difference provided that the amount so payable shall not exceed the aggregate of:

(i) The value of the work executed up to the date of determination

(ii) The value of such of the said materials as are subsequently incorporated in the work or otherwise disposed of; and

(iii) The value of any such plant and equipment disposed of less the amount already paid under the contract. Any such materials, plant and equipment as are unsold or unused when the works are completed shall be returned to the contractor.

(3) If the cost of completion added to the sum actually paid to the contractor upto the date of completion exceeds the sum which would have been payable to the contractor for due completion and the Commissioner may apply the proceeds for the sole of plant, materials and equipment provided by the contractor on the site in reduction of such excess and any deficit shall be recoverable from the contractor. If other such excess has been met, there remains any residue of the proceeds of the sole of the plant, materials and equipment or any unsold plant, machineries and equipment shall be paid or returned to the contractor as the case may be.

(4) In the event of determination of the contract an account of the death, insanity, insolvency or imprisonment of the contractor, the notice determination of contract required under Clause 1-6-8 shall be posted at the site of the work and advertised in one issue of the local dailies.

The provisions of the preceding paragraphs (1) to (3) of this Article shall then take affect, and payment shall be made and unsold plant, materials and equipment shall be refunded to the person or persons entitled to receive and give a valid discharge.

1-6-9. Special Powers of Debarring. :

These powers shall be exercised in the event of complete stoppage or abandonment of work under the orders of the Corporation Council or Government.

(a) The Commissioner shall, in addition to any other powers enabling him to determine the contract have power to determine the contract at any time by notice in writing to the contractor, and upon receipt by the contractor of the notice the contract shall be determined but without prejudice to the rights of the parties accrued to the date of determination and to the operation of the following provisions of these Article.

(b) The Commissioner shall, as soon as practicable and in any case not later than the expiration of three months from the date of such notice of the period up to the date for completion whichever is the shorter, give directions (with which the contractor shall comply with all reasonable dispatch) as to all or any of the following matters, that is to say:

(i) The performance of the further work in accordance with the provisions of contract.

(ii) The protection of the work executed under the contract in compliance with directions given under sub-paragraph (1) above.

(iii) The removal of all plant, temporary buildings and equipment from the site.

(iv) The removal of materials placed on the site

(v) The clearing of the site

(vi) Any other matter arising out of the contract with regard to which the Commissioner decide that directions are necessary or expedient.

(c) The commissioner may at any time within the period referred to in paragraph (b) herein by notice in writing to the contract vary any direction so given or give fresh directions as to all or any of the matter specified in the foregoing paragraph.

(d) In the event, of the determination of the contract under this condition there shall be paid to the contractor the net amount as ascertained in accordance with all the applicable provisions of Clause 1-7 hereof including valuation in the same manner as increased or decreased quantities, extra work and omitted items.

These shall be deducted from any sum payable to the contractor under this sub-clause the amount of all payments previously made to the contractor in respect of the contract, and the Commissioner shall have the right to retain any reserve accumulated in his possession at the date of determination until the final settlement of all claims made by the contractor.

(e) Any dispute of difference: Which may arising between the parties as to the carrying out of those conditions shall be referred to arbitration and the provisions with regard to arbitration in Clause 1-8 thereof shall apply.

1-7 MEASUREMENT AND PAYMENT

1-7-1 Measurement of Quantities: All work to be paid for at a contract price per unit of measurement shall be measured by the Superintending Engineer/Zonal Executive Engineer in accordance with the methods set forth in the relevant specifications.

The contractor shall from time to time when the required on reasonable notice by the Superintending Engineer/Zonal Executive Engineer or his representative, attend at the works in order that any measurements or check measurements of the work executed that may be necessary for preparation of a bill may be taken by the Superintending Engineer's/Zonal Executive Engineer's representative. Any such measurements or check measurements when performed and any differences arising thereon shall be duly recorded in the manner, required by the S.E.'s/Zonal Executive Engineer's representative, and the Superintending Engineer's/Zonal Executive Engineer's decision shall be final and conclusive. The contractor shall without extra charge provide assistance with every appliance and other tools and labour necessary for measuring the work. If the contractor fails to attend when so required, the Superintending Engineer/Zonal Executive Engineer shall have power to proceed by himself to take such measurements or check, measurements and that in case any decision of the Superintending Engineer/Zonal Executive Engineer shall be final and conclusive and the cost of any labour engaged for the purpose shall be recoverable from the contractor.

1-7-2 Final Payment:

It shall be accepted as a condition of the contract that the payment of the final bill to the contractor deducting the withheld amounts and his acceptance thereof shall constitute a full and absolute release of the Corporation from all further claims by the contractor under the contract.

A minimum of 10 % of contract amount to be withheld.

1-7-3 .Non - Tendered Items : In case of items of works where supplement agreement is to be entered into the following procedure will be adopted.

For items of work for which the rates can be derived from the rates for the items in the original agreement, the rates will be derived by applying the overall tender premium or discount to the rate for the new item and by applying the prorate excess or discount for the item of work, from which the rates is delivered, the lesser rate of these two will be adopted for making payment to the contractor.

For items of Work for which the rates cannot be derived from the rates for the items in the original agreement, the rates for payment will be as follows:

a).When schedule of rates were not changed during the period from the date of execution of the original agreement to the date of supplemental agreement then the rates for the supplement agreements shall be as per the prevailing schedule of rates with the tender premium or discount applied.

b).When the schedule of rates has changed during the intervening period, rate arrived at as per the new schedule of rates at the time of execution of supplemental agreements will be adopted with no tender premium applied or discount applied to this rate.

1-7-4 .Payment-Extra Items: If the Superintending Engineer/ Zonal Executive Engineer and the contractor fail to agree on a rate for payment of extra work, payment will be made on the actual cost of labour, of materials including conveyance, and local supervision solely engaged on the extra work, together with 10 percent of the total of the items as certified by the Superintending Engineer/Zonal Executive Engineer. To enable the Superintending Engineer /Zonal Executive Engineer to evaluate the extra work the contractor shall "furnish the Superintending Engineer/Zonal Executive Engineer with the connected books of account, vouchers, and other documents in support of the claim within seven days after such extra work is completed. Reasonable compensation shall also be allowed for the use of contractor's tools and plant on the extra work and for such materials as are used for staging, form work, curing, etc. If the Superintending Engineer/ Zonal Executive Engineer considers that payment of such work on

the basis of the vouchers presented is unduly high, he shall make payment in accordance with such valuation as he considers fair and reasonable and his decision in the matter shall be final, if the amount involved in the extra payment is Rs.1, 000 or less for each occasion on which such extra works are authorized.

If, in the opinion of the Superintending Engineer/ Zonal Executive Engineer a unit price or lump sum compensation for the extra work cannot be fixed at prior to execution of the work, the payment thereof shall be dealt with as provided for in the preceding paragraph.

Payment to the contractor will be made for the actual quantities only of the work, performed or materials furnished accordance with the contract, and Tender Accepting Authority shall be ordinarily permitted to vary the quantity finally ordered only to the extent of 25 % either way of requirement indicated in the tender documents. The payment will be made as per originally approved rate

1-7-5 Accounts, Receipts and Vouchers:

The contractor shall at any time, upon the request of the Superintending Engineer/Zonal Executive Engineer furnish him with all invoices accounts receipts and other vouchers that he may required in connection with the contract.

1-7-6 Fraud, Willful Neglect or Default:

No final or other certificate or payment or completion, acceptance, or settlement of account shall, in any circumstances, relieve the contractor of his liabilities for any fraud or willful neglect in the execution of the contract, or any willful or unauthorized deviation from the plans, specifications, instructions and directions for the time being upon him.

1-7-7 Unfixed Materials:

No payment or advance will be made for unfixed materials when the rates are for finished work "in situ". However payment may be allowed up to maximum 75% at the discretion of Superintending Engineer/Zonal Executive Engineer.

1-7-8 Payment and Certificates:

Payment will be made to the contractor under the certificates to be issued at reasonable frequent intervals by the Superintending Engineer/Zonal Executive Engineer. Within fourteen days of the submission of each certificate an intermediate payment will be made of a sum equal to 90 percent of the value of the work, as so certified and the balance of 10 percent will be withheld and retained as a security for the due fulfillment of the contract. Under the certificate to be issue by the Superintending Engineer/Zonal Executive Engineer. On the completion of the entire works the contractor will receive the final payment of all the moneys due or payable to him under or by virtue of the contract except security deposit, provided there is no recovery from or forfeiture by the contractor to be made under penal clause 1-6-6, 1-6-7, 1-6-8 and 1-6-9

No certificate of the Superintending Engineer/Zonal Executive Engineer shall be considered conclusive evidence as to the sufficiency of any work or materials or correctness of measurements to which it relates, not shall it relieve the contractor from his liabilities to make good the defects as provided by the contract, The contractor when applying form a certificate, shall prepare a sufficiency "A" to the satisfaction of the Superintending Engineer/Zonal Executive Engineer to enable the Superintending Engineer or the Zonal Executive Engineer, or the Assistant Executive Engineer to check the claim and issue the certificate.

1-7.9.Acceptance of Final Measurement:

The contractor agrees that before payment of the final bills shall be made on the contract, he will sign and deliver to the Superintending Engineer/Zonal Executive Engineer either in the measurement book or otherwise as demanded, a valid release and discharge from any and all claim and demands whatsoever for all mailers arising out of or connected with title contract; provided that nothing in this clause shall discharge or release the contractor from his liabilities under the contract. It is further expressly agreed that the Superintending Engineer/Zonal Executive Engineer in supplying the final measurement certificate, need not be bound by the processing measurements and payments. The final measurements of the Superintending Engineer shall be final conclusive and binding on the contractor.

1-7-10. Recoveries from Contractor:

In every case in which provision is made for recovery of money from the contractor, Commissioner shall be entitled to retain or deduct the amount thereof from any moneys that may be due or may become due to the contractor under these presents and / or under any other contract or contracts or any other account whatsoever.

1-8: SAFETY CODE:

1-8-1. Suitable scaffolds should be provided for workmen for all works that cannot safely be done from the ground, or from solid construction except such short period work as can be done safely from ladder. When a ladder is used an extra mazdoor shall be engaged for holding the ladder and if the ladder issued for carrying materials as well, suitable footholds and hand holds

shall be provided on the ladder and the ladder shall be given an inclination not steeper than ¼ to 1 (1/4 horizontal and 1 vertical)

1-8-2 Excavation and Trenching:

All trenches, 1.2m (4 feet) or more in depth, shall at all times be supplied with at least one ladder for each 30 m (100 feet) in length or fraction thereof. Ladder shall be extended from bottom of the trench to at least 90 cm (3 feet) above the surface of the ground. The sides of the trenches which are 1.5 m (5 feet) or more in depth shall be stepped back to give suitable slope or securely held by timber branching, so as to avoid the danger of sides to collapse. The excavated materials shall not be placed within 1.5 m (5 feet) of the edges of the trench or half of the depth of the trench whichever is more. Cutting shall be done from top to bottom. Under no circumstances undermining or under cutting shall be done.

1-8-3. Demolition:

Before any demolition work is commenced and also during the process of the work:

- (a) All roads and open areas adjacent to the work site shall either be closed suitably protected.
- (b) No electric cable or apparatus which is liable to be source of danger over cable or apparatus used by the operator shall remain electrically charged.
- (c) All practical steps shall be taken to prevent danger persons employed from risk of fire or explosion or flooding, floor, roof or other part of the building shall be so over loaded with debris or materials as to render it unsafe.

1-8-4.-Safety Equipments:

All necessary personal safety equipments as considered adequate by the Engineer in charge should be kept available for the use of the person employed on the site and maintained in a condition suitable for immediate use, and the contractor should take adequate steps to ensure proper use of equipment by those concerned.

(a) Workers employed on mixing asphaltic materials, cement, lime mortars shall be provided with protective foot wear, protective goggles.

(b) Those engaged in white washing and mixing or stacking cement bags or any materials which is injurious to the eyes shall provided with protective goggles.

(c) Those engaged in welding works shall be provided with welder's protective eye shields.

(d) Stone breakers shall be provided with protective goggles and protective clothing seated sufficiently safe intervals.

(e) The contractor shall not employ men below the age of 18 years and women on the work of painting with products containing lead in any form. Wherever men above the age of 18 are employed on the work of lead painting the following precautions should be taken.

i. No paint containing lead or lead products shall be used except in the form of paste of ready made paint.

ii. Suitable face masks should be supplied for use by the workers when paint is applied in the form of spray or surface having lead dry rubbed and scraped.

iii. Overalls shall be supplied by the contractors to the workmen and adequate facilities shall be provided to enable the working painters to wash during the cessation and work.

iv The contractor shall not employ women & men below the age 18 on the work of painting with products containing lead, in any form. Whenever men above the age of 18 are employed on the work of lead painting, the following principles must be observed for such use:-

1. a. White lead, sulphate of lead or products containing these pigments shall not be used in painting operation except in the form of paste or of paint ready for use.

b. Measures shall be taken whenever required in order to prevent danger arising from the application of paint in the form of spray.

c. Measures shall be taken wherever practicable to prevent danger arising out from dust caused by dry rubbing down and scraping.

2. a. Adequate facilities shall be provided to enable working painters to wash during and cessation of work.

b. Overalls shall be worn by working painters during whole of the working period.

c. Suitable arrangements shall be made to prevent clothing put off during working hours being spoiled by painting materials.

3. a. Cases of lead poisoning shall be notified and subsequently verified by a medical man appointed by the competent authorities of Corporation of Chennai.

b. Corporation of Chennai may require, when necessary a medical examination of workers.

c. Instruction with regard to the special hygienic precautions to be taken in the painting trade shall be distributed to the working painters.

1-8-5. First Aid Provision in Site.: When the work is done near any place where there is risk of drowning all necessary steps taken for prompt rescue of any person in danger and adequate provisions should be made for prompt first aid treatment of all injuries likely to be sustained during the course of the work.

1-8-6. Use of Hoisting Machines: Use of hoisting machines and tackle including their attachments, anchorage and supports shall conform to the following standards or conditions.

1. (a) There shall be of good mechanical construction, sound material and adequate strength and free from patent repair and defects and shall be kept in good repair & in good working order.

(b) Ever rope used in hoisting or lowering materials or as a means of suspension shall be durable quality and adequate strength and free from patent defects.

2. Every crane driver or hoisting appliance operator shall be property qualified and no person under the age of 21 years should be in-charge of any hoisting machine including any scaffolding winch or give signals to operator.

3. In case of every hoisting machine and of every chain ring hook, shackle swivel and pulley block used in hosting or as means of suspension the safe working load shall be ascertained by adequate means. Every hoisting machine and all gear referred to above shall be plainly market with the safe working load. In case of hoisting machine having a variable safe working load. In case of hoisting machine having a variable safe working load, each safe working load and the conditions under which it is applicable shall be clearly indicated. No part of any machine or any gear referred to above in this paragraph shall be loaded beyond the safe working load excepted for the purpose of testing.

4. In case of departmental machines the safe working load shall be notified by the Electrical Engineer-in-charge. As regards contractor's machines the contractors shall notify the safe working load of the machine to the Engineer-in-charge whenever he brings any machinery to site of work and get it verified by the Electrical Engineer concerned.

1-8-7.Risk coverage of Machines in site. Motors, gearing, transmission, electric wiring and other dangerous parts of hosting appliances I should be provided with such means will reduce to the minimum the risk of accidental descent of the load. Adequate precautions should be taken to reduce the minimum the risk of any part of a suspended load becoming accidentally displaced. When workers employed on electrical installations which are already energized insulting mats, wearing apparel such as gloves, sleeves and, boots as may be necessary, should be provided. The workers should not wear any rings, watches and carry keys or other materials which are the good conductor of electricity,

1-8-8. Maintenance of Equipments : All scaffolds, ladders and other safely devices mentioned or described herein shall be maintained in. safe condition and no scaffold ladder or equipment shall be altered or removed while it is in use Adequate washing facilities should be provided at or near places of work.

1-8-9.Saftey Measures on Display: These safely, provisions should be brought to the notice of all concerned by display on a notice boards at a prominent place at work spot, The person responsible for compliance of the safety code shall be named therein by the contractor.

1-8-10. Enforcement of Rules. To ensure effective enforcement of the rules and regulations relating to safety precautions the arrangements made by the contractor shall be open to inspection by the Labour officer/ Engineer – in Charge of the department or their representatives.

1-8-11-Contractor-No.Exemption.: Not withstanding the above clause from 1-8-1 to 1-8-11- there is nothing in these exempt the – contractor from the operations of any other Act or Rule in force.

1-9. Providing Insurance: The contractor shall have to provide a minimum insurance of man power and equipments. This insurances cover should start from the date of starting of work and should be valid upto the end of execution period. The responsibility of timely payment of the premium as well as that of lodging claims as and when situation arises will be that of contractor. All insurances which the contractor requires to enter into under the contract shall be affected with an insurer or insurers and in terms approved by the Superintending Engineer/Zonal Executive Engineer.

2. GENERAL CONDITIONS FOR ALL CIVIL WORKS

2-1 The item of works for repairing, relaying and doing patch works and other improvements are contained in detailed schedule of rates attached.

2-2 The total approximate value of works will be in all about Rs. Lakhs for each contract. This is only approximate to enable the tendered to have and idea in tendering and also for the purpose of fixing the security deposit.

2-3 The quantities of works specified are also approximate and are meant to enable the tenders to have an idea of the works while tendering.

2-4 The office schedule of rates for each item of work is noted in the attached schedule of rates and the tenderer shall carefully scrutinize these rates and tender one total single percentage less or higher on the whole of the schedule of rates for the contract he is tendering in the accompanying schedule.

This less or higher percentage tendered by the tenderer shall apply for each and every item of work of schedule of rates and shall include sales tax and all other taxes in force i.e., the less or higher percentage worked out by the tenderer should cover the sales tax and all other taxes, the tenderer may have to incidentally incur in the execution of the entire work. The accepted less or higher shall be operative on all works, viz., various

.....
.....
.....
.....

..... during the year The tenderer's less or higher percentage offered for each contract will be one single less or higher percentage applicable to each of the items of works in the relevant zones.

2-5 .PROCEDURE FOR EXECUTION OF WORK AND PAYMENT

The following procedure will be adopted:

i. The accepted tenderer will be furnished with an abstract of work to be executed from time to time and straight away asked to carry out the work.

There will be only one agreement which the accepted tenderer has to execute in the beginning for the works to be executed during the year. The work ordered to be carried out shall be commenced within three days of the receipt of the order for any particular work and completed within the time limit fixed in each individual work order and to the entire satisfaction of the Engineer or his representatives.

ii. The Contractor's bill for each individual work in each of the zone respective divisions shall be paid on completion treating each work as separate work to facilitate regular payment of the bills.

iii. Items of work executed and not fully covered in the accompanying schedule of rates will be paid based on schedule of rates subject to the contractor's tender percentage.

2-6.LUMPSUM ITEMS

Lumpsum works to be executed which are not susceptible of measurements will be paid at the actual cost of materials used and labour engaged on the works plus 10% contractor's on the relevant items of work. The contractor shall procedure proper bills for the materials used and muster roll maintained at the work spot and duly certified by the officer of Corporation in charge of the work for the labour employed The payment of lumpsum items of works shall be in accordance with clause No.59 of General Conditions of contract of T.N.B.P

2-7 –Inconvenience to Public.

The contractor shall not deposit materials on any site which will seriously inconvenience the public The Engineer in charge may require the contractor to remove any materials which are considered by him to be a danger or inconvenience to the public or cause them to be removed the contractor's cost. Any damage to work resulting from rains or from any other cause until the work is taken over by the Department, after completion will be made good by the contractor at his own cost.

2-8.REMOVAL OF EXCAVATED EARTH, SURPLUS EARTH, DEBRIS

All materials excavated by the contractor including dismantled bricks etc (not re-useable) shall be disposed off by the contractor as directed by the Superintending Engineer/Zonal Executive Engineer Surplus earth shall be removed within 3 days from excavation by the contractor for SWD works/road widening works etc. as otherwise a penalty of Rs.500/- per day will be imposed on the contractor by the department.

2-9. Charges to be paid by the Contractor: The contractor shall pay for all fees and provide water and light as required from Corporation mains or other sources, and shall pay all charges therefore for the use of the work and workmen.

The water for the works shall be free from earthy, vegetable or organic matter and from salt or other substances like to interfere with the setting of the mortar or otherwise prove harmful to the work.

2-10. TRAFFIC REGULATIONS

(a) Clause 112 of the SSRB shall apply to the whole works Tippers, trucks, water Lorries to which when not in actual use shall be drawn clear off the road, the safety to the public all precautionary measures shall be taken by way of lighting with bright red light and warning boards.

The Contractor shall maintain watchman on the works and control and regulate traffic. If an where necessary. Notice boards shall be placed in suitable locations bearing in large letters in conspicuous columns. Warning notices shall be placed at the points in the neighbourhood of the work where other roads join and across the road and at such other places and points as may be directed to enable the motorists cyclists or other vehicular traffic, avoid the obstructed road by taking alternative routes.

Extra payment will not be made for any such incidental items.

(b) Penalty for not arranging traffic regulations:

If the contractor fails to make arrangements for traffic regulations as described in condition 2-10

(a) a penalty of Rs 500- day will be imposed on the contractor.

2-11 If Cement and steel M.S. /R.T.S will be supplied to the Contractor by the Corporation, (if and when available) at the rate of Rs...../- per tonne, M.S. Rs...../- per Tonne R.T.S. Rs...../- per tone, respectively and the cost recovered from the bills of the contractor for the work. The Contractor will have to arrange for carting from the specified Corporation store yard at their own cost for carting the same to work site. The contractor's rate for the respective items involving cement and steel should inclusive the cost of conveyance from the source of departmental supply to the work spot. The contractor shall not claim any compensation for non-supply of cement and steel by the departments.

2-12 All works shall be executed in accordance with TNBP and S.S.RB unless otherwise specified. For road works as per MORTH Specifications

2-13 (i) Supplying steel rods including cutting, bending hooks, cranking, fabricating and assembling laying in exact position tying with 16 or 18 B.W.G. for R.C.C. works etc., complete for R.C.C. works.

(ii) Centering for R.C. Work should be provided with steel plates, Resets used for scaffolding and centering should be firmly fixed to the ground and in no case shall centering be supported on bricks or on loose materials, etc., Double scaffolding should be used as per M.D.S.S. if required by the Exe. Engineer (Z.....) of the works.

2-14 Sand Quarry : Only sand from P.W.D notified quarries shall be used.

2-15 The detailed dimensions of foundations, etc., and dimensions of all R.C. Works , all as per IS code, in the plans are subject to alteration during execution.

2-16 As per Govt. orders issued in GO. Regd No. 985 Rural Development and Local Administration Department dated 14-5-1979 that for the quantity of cement, steel etc., wasted or used in excess of prescribed quantities (by more than 5%) or not returned in good condition by the contractor the recovery of the cost will be double the issue rates”.

2.17 Note : The weight of reinforcing steel in all the “ Supplying Steel roads and fabricating” items shall be calculated on the section weight of the respective rods after measuring the finished and fabricated steel work laid insitu before the laying of concrete is ordered by the Engineer. The individual bars with measured and weight shall be weighted per metre as noted hereunder.

Diameter of bar in Millimeter	Weight per running meter in Kilograms
8	0.39
10	0.62
12	0.89
16	1.58
20	2.47
25	3.85
32	6.32

For Sections other than those specified above weights standard reference and Hand books or tables shall be adopted.

The bending and tying with and supporting device will not be measured and the weight of such wires, etc., will be ignored. The rate per quintal tendered shall include all labour, materials, tools and equipments, bending and fabricating to shape and doing all the work involved in handling and placing the specified reinforced steel, tying and securing complete in place with all necessary stays and supported devices if and when required. However the weight of rods used in works may be weighed by the respective Assistant officers on a representative sample to make sure that the size and coefficients adopted for various sections do not differ from the one furnished above

2-18 The rates should be quoted both in words and figures. No quotation or tender will be considered unless the rate is furnished both in figures and words. If there is any correction in the rate, it should be attested by the contractors and also by the officer concerned at the time of opening of the quotation or tender. In case of any discrepancy is found between the rates less (or) higher percentage in words and figures the lower value only be taken as tender rate.

2.19 In case of any discrepancy found between the quoted rates percentage in words and figures, the lower value only be taken.

2.20. In case of any discrepancy found between the words & figures for the rebate amount offered for reusable materials to be retrieved from the structure proposed to be demolished the higher value only be taken.

2-21.The Commissioner may put an end to the agreement at his option at any time, and in the case of bad work of material, the Engineer may remove the same and have it replaced, deducting the value of the work, rejected or materials removed, or the cost of replacing the same, as he may think proper from any amount due that may became due to the party making this tender.

2-22. The levels furnished in the plan are based upon the investigations done by the Department. If any change in level, water levels, etc., and found during actual execution, the contractor are bound to accept them and they are not eligible for any extra claim for such change in levels or otherwise.

2-23. As soon as the Contract is accepted, the contractor should give a program of work which he proposes to adopt for execution. The progress of work should be conformity with the rate of progress specified under clause 1-16 of tender notice.

2-24. The Contractor shall be absolutely and solely responsible for injury or damage to person and property of any description whatever, which may be caused by or result from the execution of the works whether these may have been carried out skillfully and strictly in conformity with the provision of the specification or not.

2-25. Any old iron work, pipers, bricks or other materials met within the works and which require to be removed for the construction of the work shall be held to belong to the Corporation and required by them Exe. Engineer() may have them removed by the Contractor without any extra cost.

2.26. Any coins, curiosities or antiquities or treasure trove found during the constructions of the works shall be immediately delivered to the Executive Engineer on behalf of the Corporation.

2-27.The contractor at his own expense shall disinfect with chloride or lime or other storing disinfectant all offensive matter immediately it is taken out of the trenches and shall cart away or cover up such matter as soon as possible.

2-28.The contractor shall at his own cost after competition of the work remove all water and all materials or rubbish of every description which may have collected in the works and find a deposit, therefore and anything which may have collected within the work, during the period of maintenance shall also be removed before the works are finally accepted by the Corporation.

2-29.If the tenderer is a registered contractor of this department and if certificate for the current year had already been produced by him during the calendar year in which the tender is made, it is compulsory for renewal of the same.

2-30.The materials required for road works shall be supplied and stocked at the site; Measurements will be recorded then and there and check measured by the competent engineers before using them for works.

2-31.Based on site conditions, the contractor should raise the manhole doors, valve doors, etc. to the required levels. Also the Contractor should provide cable ducts and execute other works whenever is found necessary during the time of execution as directed by the Exe. Engineer.

2-32. No correspondence from the Tenderer's will not be entertained after the opening of the tenders before the award of the contract, besides debarring the contractor for a specified period by the competent authority.

2-33.Tenders with conditions stipulated may not be considered.

2-34.In respect of bituminous course continuous record of the mixes shall be maintained at site/ plant site for tallying the proportions of the materials and ensuring the correct rate spread.

2-35.SITE INSTRUCTION BOOK

A site instruction book shall be kept at the Corporation of Chennai Office on the site of the work. As far as possible, all orders regarding the work are to be entered in this book all entries shall be signed and dated by the Corporation of Chennai Officer in direct charge of the work and by the contractor by his representative. In important cases, the Executive Engineer or the Superintending Engineer/Zonal Executive Engineer will countersign the entries, which have been made. The site instruction book shall not be removed from the site except with the written permission of the Executive Engineer.

2-36.PERMISSION FOR EXECUTING THE WORKS DURING THE HOLIDAYS/NIGHTS

Name of work.....

Department.....

Location.....

Date.....

Dn..... Unit.....

Zone.....

Date & Duration of Work
to be done during Holidays/ Nights

Name of the Contractor

Name of the Departmental A.E./ J.E.

Signature of Contractor

Signature of the E.E./ Superintending Engineer

3.GENERAL SPECIFICATIONS

3-1.MATERIALS

General Provisions:

Materials should normally be supplied from the sources specified. However, materials complying with these specifications will be accepted from any source of supply but the Superintending Engineer/ Zonal Executive Engineer/Executive Engineer reserves the right to reject the entire output of any source from which it is impossible to get a continuous supply or when conditions are such that the use of unfit material cannot be prevented except by extraordinary methods. The materials conform to the specifications referred to in this chapter.

3-1-1.Conveyance to Site:

Materials shall be brought to the site sufficiently in advance of construction. The contractor shall be responsible that vehicles used for transporting materials do not drop any of their contents on the road. Superintending Engineer/Zonal Executive Engineer will order the removal of such material at the expense of the contractor in cases of neglect. Carts shall invariably be provided with tail boards.

3-1-.2 Storing:

Whenever a mixture of aggregates composed of two or more standard sizes of aggregates is specified for any work, the component parts shall be stored separately. Likewise, aggregates obtained from different sources; or for different purposes, whether of one standard size or not shall be stored separately. Materials shall not be stored unless they conform in all respects to the relevant specifications.

3-1-3 Measurement and Payment:

Materials as governed by the specifications will not be measured for payment nor paid for as separate items, but the cost shall be considered as included in the price paid for the relevant contract item of work.

3-2.COARSE AGGREGATE

3-2-1 Coarse Aggregate for Portland cement Concrete:

The term 'coarse aggregate' shall mean an aggregate most of which is retained on a 4.75mm (3/16") B.S.S. sieve contains over so much finer materials as is permitted for the various types described in this specifications. Coarse aggregates for Portland Cement Concrete shall comply with the following requirements.

a).Description :

Coarse aggregates consist of broken granite having clean, hard, strong, dense and durable fragments, free from adhering coatings and conforming to the requirements of this specifications. Flaky and elongated pieces should be avoided.

b).Deleterious Substance :

Aggregates shall contain no harmful materials in such quantities as to affect adversely the strength and durability of the concrete. Mica, shale or similar laminated materials shall not be present in such form or in such quantities as to affect adversely the concrete as ascertained by appropriate tests.

(c) Grading :

The aggregates shall be composed of different size fractions in the proportions herein set forth. Grading of the materials from anyone source shall be reasonably uniform. The grading of aggregates for a given work shall be specified in the Schedule 'A'. In case concrete resulting from a mixture of aggregates approaching extreme limits of gradation is not workable or when finished does not exhibit a proper surface due to an excess of particulars approximately 3mm to 12.5mm (1/8" to 1/2") size either a fine aggregate having a sufficiently greater percentage of the materials or a coarse aggregate having a small percentage of the materials shall be used if required by the Superintending Engineer/ Zonal Executive Engineer .

3-2-2.Storage :

Aggregates shall be stored at the site of the work in such a manner as to prevent deterioration or contamination. Any material which is deteriorated or has been damaged shall be immediately removed from the site. At the time of use, aggregates shall be free from all foreign materials.

3-3 L.C.C ratio shall be! 5:10.

3-4.FINE AGGREGATE

3-4-1.Fine aggregate for Portland cement concrete:

The term fine aggregate shall mean an aggregate most of which passes a 4.75mm (3/6") B.S.S. sieve and contains only so much coarser materials as is permitted for the various types described in this specification, and as notified by P.W.D. Fine aggregate for Portland Cement Concrete shall comply with the following requirements:

(a) Description:

Fine aggregates shall consist of natural sand composed of fine granular material resulting from the reduction of rock by the action of the elements or sand produced by the crushing of rock. The particles shall be clean, hard, strong and durable.

(b) Deleterious Substance:

Aggregate shall contain no harmful materials as to affect adversely the strength or durability of the concrete.

(c) Grading:

Fine aggregate when tested by means of laboratory sieves having square opening, shall conform to the grading requirements set forth below :

Grading limits for fine aggregates for Portland Cement Concrete

Sieve (ASTM)	I.S.	Percentage by Weight by passing Natural Sand	Crushed Stone Sand
3/16" (No.4)	480	95 – 100	90 – 100
(No. 8)	240	70 – 95	60 – 95
(No. 16)	120	45 – 85	40 – 80
(No. 30)	60	25 – 60	20 – 50
(No. 50)	30	5 – 30	5 – 30
(No. 100)	15	0 – 10	0 – 15

The gradation of fine aggregates from any one source shall be reasonably uniform. For the purpose of determining the degree of uniformity, a Fineness Modulus determination shall be made upon representative samples of fine aggregates from such sources as are proposed for use. Fine aggregates having a variation in Fitness Modulus greater than plus or minus 0.2 from the Fineness Modulus of the Representative samples may be rejected.

In case the concrete resulting from a mixture of aggregate approaching the extreme limit of gradation is not workable or when finished does not exhibit a proper surface due to an excess of particles approximately 25mm to 12.5mm (1" to 1/2") in size, either a fine aggregate having a sufficiently greater percentage of the fine material or a coarse aggregate having a sufficiently smaller percentage of the fine aggregate shall be used.

3-4-2 Source

The sources for the Fine Aggregate is as notified by PWD..

3-4-3 – Storage

Aggregates shall be stored at the site of the work in such a manner as to prevent deterioration or contamination. Any material which is deteriorated or has been damaged shall be immediately removed from the site. At the time of use, aggregates shall be free from all foreign materials

The Sources for the fine aggregate is as notified by PWD.

3-5 MORTAR SAND

3-5-1.Description :

The sand to be used shall be composed of hard silicious matter. It shall be clean and of sharp angular grit type. The sand shall be screened before use. If the sand brought to the site is dirty, it must be washed clean in water.

3-5-2 Screening :

For mortar, ordinary plaster and brick work sand shall be of such a nature as to pass through a sieve of 64 meshes per sq.m. (sq.inch)

3-5-3 .Source,

As notified by PWD.

3-5-4- Storage.

Aggregates shall be stored at the site of the work in such a manner as to prevent deterioration or contamination. Any material which is deteriorated or has been damaged shall be immediately removed from the site. At the time of use, aggregates shall be free from all foreign materials

3-5-5.BRICKS

(a) Bricks shall be of first class and table moulded, of uniform size, shape and colour (generally deep red or copper) and must be well burnt so as to give a clear ringing sound when struck. They shall not break when thrown on wall or against other bricks. They shall be clean, whole and free from flaws, cracks, stones and under burnt lumps of any kind especially lime. They shall have sharp edges and angles and even surfaces.

(b) Bricks which when soaked in water for twenty four hours, absorb more water than 1/5th of their dry weight shall be rejected.

(c) Unless otherwise ordered or permitted by the Superintending Engineer/Zonal Executive Engineer, standard size for wall bricks is to be adopted.

(d) Method of Manufacture - The raw bricks shall be moulded of such a size, that the burnt bricks shall have the specified dimensions. Only well matured clay free from all lumps shall be used and this clay shall preferably be passed through a pugmill. The bricks shall be moulded in wooden moulds which must be renewed as often as the Superintending Engineer may order. The bricks shall be burnt in chambers of an approved type. The above specifications for brick making shall be burnt in chambers of and approval type. The above specifications for brick making shall be complied with by the contractor in cases where he supplies his own bricks or he is to guarantee such compliances by the manufacturers in cases where he purchases bricks.

3-5-6.CEMENT

3-5-7.Requirements :

All Portland cement shall conform to the requirements of Indian Standard Specifications I.S. 269-1951.

3-5-8.Storage :

All cement shall be stored in suitable weather proof shed, which will protect the cement from dampness. Provision of storage shall be ample, to cope with the issue of cement by the department and the delivery of cement as received shall be separately stored in such a manner as to provide easy access for the identification and inspection of each delivery. The contractor shall keep accurate records of the deliveries of cement and of its use in the work copies of these records shall be supplied to the Superintending Engineer /Zonal executive Engineer in such form as may be required.

3-5-9.Rejection :

Cement may be rejected if it fails to meet any of the requirement of these specifications. At the time cement is incorporated in the work, it shall meet the requirements as to quality specified. Cement which has become partially set or which contain lumps shall not be used. Unless it complies with the specifications after reclaiming in a manner satisfactory to the Superintending Engineer/Zonal Executive Engineer The use of salvage cement will not be permitted in any part of the work. Different kinds or brands of cement, of cement of the same brand from different mills shall not be used alternatively in anyone class of construction.

3-6.WATER

3-6-1.Source

This specification covers the requirements of water used with cement in concrete or mortar and water used for curing concrete.

3-6-2.Quality

Water shall be clean, clear and free from traces of oil, acid alkali, salts and other deleterious substances and in short generally fit for drinking.

3-6-3.Approval of Source :

Water shall be obtained from a source approved by the Superintending Engineer/Zonal Executive Engineer/ Executive Engineer Water from shallow muddy or marshy surfaces shall not be used.

3-6-4.Containers :

The containers for transport, storage and handling of water shall be clean so as not to cause contamination or deterioration in the quality of water.

3-7.STEEL

3-7-1.Description :

Reinforcement bars shall conform to the specifications and be of the shape and dimension shown in the plans.

3-7-2.Materials :

Reinforcement bars and annealed (binding wire) shall conform to the respective Indian standard specification as given below :

Reinforcement bars	I.S. 432-1953
Mild steel wire, annealed	I.S. 280-1951

3-7-3.Steel List :

Detailed steel lists and bending diagrams shall be furnished by the Superintending Engineer. The contractor should satisfy himself about the lists before fabricating.

3-7-4.Storage :

Reinforcing steel shall be stored under cover and protected at all times from injury. All bars of the same designation shall be assembled in racks and distinctly marked.

3-7-5.Cleaning :

Reinforcing steel, before being placed in the forms shall be thoroughly cleaned of loose mill and rust scale, mortar, oil, dirt and of coatings of any character that would destroy or reduce the bond.

3-7-6.Bending :

Reinforcing steel shall conform accurately to the dimensions shown on the plans. Bars shall not be bent or straightened in a manner that will injure the materials. Bars with kinds or bends shall not be used.

Bars shall be bent cold to the shape and dimension as shown in the drawings or as directed by the Superintending Engineer using bar bender operated by hand or power to obtain the proper radii of bends. The radii of all bends shall conform to the requirements given below :

The internal radius expressed in bar diameters of a bend in a reinforcing bar shall not be less than the value obtained by dividing the stress developed in the steel at the commencement of the bend by four times the permissible stress in the concrete in direct compression where the minimum concrete cover is used, and not less than two-thirds this value where conditions are such that there is no danger of splitting the concrete.

3-7-7.Placing :

Only reinforcing rods conforming to the appropriate size and shape shall be accurately placed in exact positions shown on the plans, and shall be firmly and securely held during placing and setting of concrete by wiring at intersections with S.W.G. No. 16 and 18 annealed wire and by using stays, blocks or metal chairs, spacer, metal hangers, supporting wires and other approved devices at sufficiently close intervals so that the bars will not sag between supports nor be displaced during placing of concrete or by any operation over the work. Placing bars in layers of fresh concrete where the work progresses for adjusting bar spacing will not be permitted. The use of pieces of broken stone or bricks and wooden blocks will not be permitted. Layers of bars shall be separated by the precast mortar blocks or other approved devices.

Special care shall be exercised to prevent any disturbance of reinforcement in concrete that has already been placed. The reinforcements after being placed in position shall be maintained in a clean condition until it is completely embedded in concrete. Bars shall be accurately placed as shown in the plans.

Sufficient concrete coverage shall be provided to protect reinforcement from corrosion as indicated in the plans. All protruding bars from concrete to which other bars are to be spliced and which are likely to be exposed for an indefinite period shall be protected from rusting by a thick coat and neat cement grout.

3-7-8.Splicing :

Bars shall not be spliced except as shown on the plans or as directed by the Superintending Engineer. Splices of tensile reinforcement at points of maximum stress and splicing of adjacent bars shall be avoided. Splices shall be staggered as far as possible. Where bars are spliced they shall be lapped at least forty five diameters. In lapped splices, the bars shall be placed in contact and wired together.

3-7-9.Welding :

Whenever the plans and specifications call for welding of joints in reinforcement bars in lieu of lapping them, the bars shall be butt welded so as to transmit their full strength. Welded joints should preferably be located at positions where the steel will not be subject to more than 75% of the maximum permissible stresses and the welds should be so staggered that any one section not more than 50% of the rods are welded. Only electric welding using a process which will exclude air from the molten metal be accepted. Welding shall conform to Clause No. 4-21.

3-7-10.Inspection :

No concrete shall be deposited until the Superintending Engineer/ Zonal Executive Engineer has inspected the placing of the reinforcement steel and given permission to place concrete. The concrete placed in violation of this provision will be rejected.

Accurate records shall be kept at all times of the numbers, sizes, length and weights of bars placed in positions or for the different parts of the work and verified before placing concrete.

3-7-11.Method of Measurement :

The weight of reinforcing steel incorporated in concrete and actually in place or shown on the plans or as directed by the Superintending Engineer/Zonal Executive Engineer will be determined correct to one kilogram on the following basis. The lengths of various sizes of rods will be measured after placing in position and weight calculated.

For the purpose of calculating the weight of rods placed in position the weight per foot length of the rods of each size shall be determined by actual weight of sample taken from each consignment of approximately 10 tones.

When the bars are supplied by the manufacturers on the basis of section weight, then section weight shall apply.

3-7-12.Basis of Payment : Reinforcing steel placed as shown on the plans or as directed by the Superintending Engineer/Zonal Executive Engineer will be paid for at the price per metric ton of reinforcing steel as provided in the contract.

The price paid per tonne of the reinforcing steel placed shall include full compensation for furnishing all labour, materials, tools and equipments, bending, welding, joints and fabricating to shape and doing all the work involved in handling and placing the specified reinforcing steel, lying and securing complete in place will all necessary stays and supporting devices as directed by the Superintending Engineer/Zonal Executive Engineer and shall include the cost of steel and all wastages.

Full compensation for furnishing all the wires and supporting devices, stays and chairs shall be considered as included in the prices paid for reinforcement steel and no additional compensation will be allowed for such work.

3-8.COVERS FOR CURING AND PROTECTING CONCRETE

3-8-1.Description :

Covers for curing and protecting concrete shall meet one of the following requirements :

3-8-2.Burlap :

Burlap used for curing concrete shall be made of loose fiber and shall weigh when dry not less than 7 ounces per square yard.

3-8-3.Cotton or Jute mats :

Cotton or Jute mats for curing concrete shall be one / ply sheets of cotton felt or jets felt or other filler suitably covered on both side with burlaps or coarse cotton fabrics. The mats shall weigh not less than 22 ounces per square yard when dry and shall absorb twice their weight of water.

3-8-4.Ponding :

The bunds shall be of clay and not less than 50mm (2") high. A minimum of 25mm (1") of water shall be maintained at all times over the surface.

3-8-5.Wet Earth :

Wet earth for curing shall consist of a layer of sandy soil not less than 50mm (2") thick kept saturated with water at all times.

3-8-6.Tarpaulins :

Tarpaulins or other water-proof cloth shall be used for protecting green concrete from rain. They shall be of quality as will keep off rain water effectively.

3-8-7.Prohibited Materials :

Straw, old and torn jute sacks shall not be used for curing.

3-9.GRAVEL

It is composed of rock particles, sand, silt and clay occurring naturally in deposits, free from dirt and foreign materials. It shall not contain any lumps of stones larger than 20mm gauge. A small natural admixture of clay upto 10 percent is not objectionable.

3-10.EARTH FOR FILLING THE EMBANKMENT

3-11.Description :

The earth for filling in between the retaining walls shall be good sandy earth with clay content not exceeding 30% and free from rubbish, rank vegetation and other decayed matter.

3-12.Source, Conveyance, Storing, Measurements and Payment :

The Contractor shall make his own arrangements for the source of the earth. For conveyance, storing, measurement and payment, Clause No. 4-1 shall apply.

3-13.FOUNDATION EXCAVATION AND FILL

3-14.Description :

Foundation excavation shall include the removal of all material of all kinds of soil except rock necessary for the construction of foundation and substructures in accordance with the plans or as directed by the Superintending Engineer/Zonal Executive Engineer. It shall include the furnishing of all necessary equipment and the construction of all cribs, cofferdams, dewatering, pumping, shuttering, etc., which may be necessary for the cofferdams and cribs and the placements of all necessary back fills and the disposal of any surplus materials as here in after specified.

The rights of way within the limits of structure shall be cleared of such trees, stumps bust and other perishable matter as the Superintending Engineer/Zonal Executive Engineer may direct. All such material shall be burnt or otherwise removed from the right of way as directed.

The cost of clearing of right of way within the limits of structure shall be included in the price bid for the various items of contract and no other payment will be made therefore.

3-15.Excavation :

Excavated materials is not to be placed nearer than three feet from the outer edges of the excavation but shall be placed any where, as may be ordered by the Superintending Engineer/ Zonal Executive Engineer without extra payment.

3-16.Preparation of Foundations for Footing :

The bottom of the foundation pits shall be bets leveled in all directions and before any concrete is put in, shall be well watered and thoroughly rammed. The foundation trenches shall be dug out to the exact width of the lowest step of the footings and the depth shall be in accordance with the plans, or as may be otherwise ordered by the Superintending Engineer/Zonal Executive Engineer. The sides shall be left plumb, if the nature of the soil admits of it, but when the soil appears treacherous or likely to fall in, the sides shall be sloped or shored up carefully to the satisfaction of the Superintending Engineer/Zonal Executive Engineer. When different foundation levels are necessary, the trenches shall be taken in horizontal terraces dug-out square. If by the contractor's mistake the excavation is made deeper or wider, than shown on the plan, the extra width or depth shall be made up with concrete and not with earth or other material, at the cost of the Contractor.

3-17.Inspection :

After each excavation is completed, the contractor shall notify the Superintending Engineer/ Zonal Executive Engineer and no concrete shall be placed until the Superintending Engineer/Zonal Executive Engineer has approved the depth of excavation and the character of the foundation material.

3-18.Pumping :

Pumping from the interior of excavated pit shall be done in such a manner as to preclude the possibility of any portion of the concrete materials being carried away. No pumping will be permitted during the placing of concrete, or for a period of at least 24 hours thereafter, unless it be done from a suitable sump separated from the concrete work, by a water-tight wall. In the case of deep excavation involving sub-soil water, a ring of interlocking sheet piles have to be sunk and the underground water completely pumped out before taking up foundation operations. Further this work has to be carried out as per TNBP and S.S.R. B. No separate payment will be made for pumping items.

3-19..Disposal of Excavated Materials :

All materials excavated by the contractor shall be disposed off as directed by the Superintending Engineer so as to leave the site in a neat condition. Material suitable for backfilling shall be used for that purpose to extent required to completely backfill the structure to the original ground level. Material suitable for approach fills, and not required for back fill shall be placed in the approach fills. Material not suitable for back filling or approach fills shall be disposed off as directed by the Superintending Engineer/Zonal Executive Engineer.

3-20.Back Filling :

The contractor shall back-fill completed structures in accordance with the following requirements.

No back-filling shall be placed against structures until permission shall have been given by the Superintending Engineer/Zonal Executive Engineer or 14 days after the concrete has been placed. The trenches or other excavations shall be filled up with the excavated earth carefully rammed, in regular layers of not more than 230mm (9") in thickness and compacted and consolidated by the addition of necessary water to each layer.

3-21.Method of Measurement and Payment :

Payments for excavation shall be made at the unit rate agreed upon for the actual quantity excavated in conformity with the plans or directed by the Superintending Engineer/ Zonal Executive Engineer but no payment shall be allowed for the measurement, which is outside of the volume bounded by vertical planes 450mm (18") outside of and parallel to the next lines of the footing.

Excavations for structures measured in its original position by the cross section method shall not include water or other liquids, but shall include mud, muck and other similar semi-solids.

The top and bottom limits of completed volume shall be the original ground surface and the bottom of the completed footing. Individual quantities shall be worked out to the nearest 0.028m (1 cft.) and the total of 1 set nearest to the 0.28m³ (10 cft.).

When it is necessary in the opinion of the Superintending Engineer/Zonal Executive Engineer to carry the foundation below the levels shown on the plans, the excavation for the first 915mm (3 feet) of additional depth will be included in the item, 'Foundation excavation' for which payment will be made at contract unit prices.

3.23. EMBANKMENT

3-24. Description :

This work shall consist of the constructions embankments by depositing, placing and compacting materials, in accordance with the requirements of the specification and in conformity with the lines, grades and cross sections, shown on the plans.

3-25. Materials :

Material for the embankment is good earth suitable for the work. For the supply of good earth the contractor should make his own arrangements for the source.

3-26. Equipment :

The equipment used in the construction of the embankment shall comply with the following general requirement :

- (a) Equipment for digging, moving and spreading earth.
- (b) Power Roller : The power roller shall be a three wheel general purpose type. The pressure per inch width of rear wheel shall not be less than 147kg (325lbs) under working conditions.
- (c) Water lorries fitted with spray bars or other satisfactory means of applying water controlled amounts. If approved by the Superintending Engineer alternative equipments supplemented by manual labour may be used in lieu of equipment listed above.

3-27. Construction Methods

The methods used in performing the work shall conform to the following requirements:

(a) Preparation of the Existing Services :

The full width of the base of the embankment shall be cleared of all trees, shrubs, weeds, grass and vegetable mould. The root shall be thoroughly grubbed up. Loose stones, rubbish of all sorts and all sod stuff must be removed from the surface to be covered and deposited outside the beds or disposed off as the Superintending Engineer/ Zonal Executive Engineer may direct. Ant hills are to be completely dug out and queen ants destroyed before the work is started.

(b) Placing Materials :

The embankments filled with earth shall be constructed in layers not exceeding 6 " inches and leveled, parallel to the finished grade and extending the full width of the embankment and building up of embankment by dumping the material at the ends is always prohibited. Throughout the work in each layer, the outer portion of the embankment shall be kept lower than the middle. Each layer of earth shall be compacted with power rollers or suitable mechanical equipment to be approved by the Superintending Engineer/Zonal Executive Engineer and to guarantee a uniform dry density of not less than 1842.13 kg/m³ (115 lbs/c.ft) throughout the compacted fill in each layer. The compaction of the earth shall be carried out only under optimum moisture content condition in the earth. On resuming work after one interval, if the previously compacted surface has dried up or hardened, it shall be moistened and scarified before any fresh material is placed on it.

Areas inaccessible to rollers around the retaining walls, shall be built in continuous layers not more than 100mm (4") deep and each layers shall be thoroughly compacted with mechanical or manual tampers.

3-28. Method of Measurement and Payment :

The payment for earth fillings shall be made only on the compacted quantity. The quantity shall be arrived at by taking levels on each occasion. The difference in levels between the compacted surface and the original ground level shall be taken to computer the quantity of earth for the purposes of payment. On no account shall the quantity of earth, excavated or carted from the different sources be taken into consideration for payment.

The Contractor is expected to make due allowance for compaction of earth to base his tender rate, as the payment will be only for the compacted quantity of earth as defined in the respective schedules.

The rate should include full compensation for performing all work required under embankments and for furnishing all necessary equipment, tools, labour and other items incidental to embankment.

3-29. BRICK WORK

3-30. Materials :

The materials to be furnished and used shall conform to the requirement set forth in the specifications for the several parts of the completed structure. Specific reference to important items are as follows :

Bricks – Should conform to Clause No. 3-4

Cement – Should conform to Clause No. 3-5

Sand - Should conform to Clause No. 3-2

3-31. Construction Method :

No four course of brick-work, with three joints, shall exceed in height, when built, one inch more than the same bricks piles upon one another without mortar. The bricks are to be well soaked in water before use on works, in proper through so as to be thoroughly wet when laid. The cessation of the bubbles through the water is an indication of saturation being complete.

For ensuring thorough soaking of the bricks every one or two brick layers or more as necessary, shall be provided with tubs for use. The wall of structures shall be carried up regularly in all cases 1" when the nature of the work will admit of it not leaving any part 915mm (3 ft.) lower than another. Horizontal courses shall be straight, level and even and faces of walls smooth and plumb. A straight edge and a plumb-bob shall be used for constant checking during progress of the work. No brick-bats shall be permitted to be used except when necessary for obtaining the dimension of the different course or for obtaining the specified bond. All unfinished work must be raked back in course unless otherwise directed and when new work is to be jointed to it the surface of unfinished work must be cleaned and wetted. The bricks shall be laid by placing sufficient mortar on the wall and forcing every brick into it in such a manner as to completely fill every joint with mortar whether at the bottom, side or end of the brick. The mortar to be used shall be that specified for the relevant schedule items and shall comply with the specification for the mortar specified. The bond used shall be English and shall be carried throughout the work. At all angles forming the junction of any two walls, the bricks shall, at each alternate course be carried into each of the respective walls, so as to thoroughly unite the work. When the faces are to be plastered, the joints shall be well raked out before any plaster is laid on should the plaster from want of proper joint ranking detach and fall off from the brick work, the contractor shall strip off the plaster bodily to the extent ordered by Superintending Engineer/Zonal Executive Engineer and shall re-do the work properly at his own expense.

All requisite scaffolding shall be provided at the contractor's expense and shall be double i.e., must it have two sets of upright supports. Care must be taken to ensure the safety of the work people and the contractor must comply with such instructions as the Superintending Engineer may issue to ensure such safety. The contractor will be entirely responsible for any damage or injuries to person or property resulting from ill-erected scaffolding, defective ladders, or otherwise arising out of his default in this respect.

The brick work for the retaining wall shall proceed side by side with the depositing and compacting of earth between the retaining walls. At no time shall the brick-work be constructed more than 405mm (1'-4") above the compacted earth. In the retaining wall weep-holes shall be provided at suitable intervals as instructed during execution, with the inner surface of the weep holed plastered 20mm (3/4") thick in cement mortar 1:4 crouched rock of grades in different layer shall be provided at the inner end of the weep-holes to prevent the choking of the weep-holes to have full drainage. No extra payment will be made for this and no deductions will be made for this in the brick work.

3-32. Measurement and Basis of Payment :

The quantity of the item which constitute the completed and the accepted structure will be measured for payment according to the provisions of the contract and in terms of the unit provided therein. Only accepted work shall be measured for payment and the computations of the quantities thereof will be based on the dimensions shown on the plans or ordered in writing by the Superintending Engineer/Zonal Executive Engineer.

The quantity measured will be paid for at the contract unit price. The contract unit price shall be payment in full furnishing all materials, labour, equipment, scaffolding materials, tools and incidental necessary to complete the work as specified.

3-33. BLUE GRANITE ROUGH STONE PACKING FOR REVETMENTS, ETC.**Gravel Backing:**

The surface to receive the gravel backing shall be nearly trimmed to the proper slope free from all vegetations and profusely wetted and rammed before gravel is laid on.

Standard gravel shall then be mixed with water and worked with manvetties, till it can be formed into stiff plastic balls. Gravel so mixed shall be carried in baskets to where it is to be laid and placed in a single layer to give 150mm (6") in finished thickness and shall be well rammed in position with flat wooden or iron rammers.

The finished surface of gravel should be left untouched until the gravel dried up and does not show signs of yielding.

3.34 .Rough Stone Packing:-

The stones shall be preferably sound, as regular in shape as possible and their lengths equal to the thickness of the required revetment and each stone shall not be less than 0.014m³ (1/2c.ft).

The stones shall be laid closely in position on the prepared bed and firmly set with the finished surface of the packing. The stones shall be laid breaking joint as far as possible. The stones are to be placed perpendicular to the finished surface, (i.e.) perpendicular to the slope. The interstices between adjacent stones shall be filled in with stones of the proper size, well driven with crowbars to ensure tight packing and complete filling of all interstices. Such filling shall be carried on simultaneously with the placing in position of the large stones and shall in

no case be permitted to fail behind. The final wedging shall be done with the largest sized chip practicable each chip being well driven home with a hammer so that no chips possible of being picked up or removed by hand.

8. SCHEDULES

SCHEDULE - A

SCHEDULE OF RATES AND APPROXIMATE QUANTITIES

a) The quantities given here are those upon which the lump-sum tender cost of the work is based but they are subject to alternations, omissions, deductions or additions as provided for in the conditions of this contract and do not necessarily show the actual quantities of work to be done. The unit rates noted below are those governing payment for extras or deductions or omissions according to the conditions of the contract, as set forth in the Preliminary Specification of the S.S.R.B/T.N.B.P. and other conditions or specifications of the contract.

b) It is to be expressly understood that the measured work is to be taken net (not **withstanding any custom or practice to the contrary**) **according to the actual quantities when** in place and finished according to the drawings or as may be ordered from time to time by the ----- and the cost calculated by measurement or weight at the respective prices, without any additional charge for any necessary or contingent works connected therewith. The rates quoted are for works holistic and complete in every respect.

CORPORATION OF CHENNAI
ABSTRACT FOR STORM WATER DRAIN

PWC NO.3372

TENDER SCHEDULE

Dismantling 600x750mm and Reconstruction of RCC Box type storm water drain of size 900x900mm along Nallaiah Street from Barrakka Road to Subbarayan Main Street in Dn-59,Zone-IV.

Year of Rate : 2008 - 2009

Sl. No.	Quantity		Description	Rate Rs. P. (N)	per	Amount
1	439.82	sq.m	Picking existing black top surface for 2 cm to 10 cm thick	22.40	sq.m	9851.97
2	49.63	cu.m	Dismantling of RCC Slab	357.10	cu.m	17722.87
3	101.47	cu.m	Dismantling the existing brick or stone masonry work in cement mortar under 3m high including carefully clearing the debris etc., complete.	72.60	cu.m	7366.72
4	111.61	cu.m	Dismantling Plain Cement Concrete work and clearing the debris etc., complete.	124.63	cu.m	13909.95
5	105.75	cu.m	Desilting of Storm Water Drain	76.00	cu.m	8037.00
6	214.75	cu.m	Earth work excavation in all classes of soils such as hard stiff clay, black cotton soils, red earth, shale, murams, ordinary gravel stone, earth and earth mixed with 50% but not in hard rock with an initial lead of 10m and lift of 2m including hand dewatering etc.,	63.30	cu.m	13593.68
7	36.93	cu.m	Cement concrete work with Blue granite metal 40mm gauge in cement mortar 1:4:8 (one cement four clean river sand and eight 40mm B.G.Metal) for foundation including watering, ramming and consolidating etc., complete	1916.70	cu.m	70783.73
8	1188.81	sq.m	Supplying and erecting centering for sides and soffits including supports and shuttering upto 3m high for plane surface such as side slabs of RCC boxing and similar vertical RCC slab, etc., with all cross bracings using mild steel sheets of size 90x60cm and 10gauge stiffened with welded mild steel angles of size 25x25x3mm for boarding laid over Oak (country wood) joists of size 10x6.5cm spaced at about 90cm centre to centre and supported by casuarina props of 10 to 13cm dia spaced at 75cm centre to centre etc., complete	302.50	sq.m	359615.03
9	167.58	cu.m	Providing vibrated reinforce controlled Ready-mix cement concrete M 20 design mix (to be designed with the material to be used) using 20mm ISS size HBG metal including cost and conveyance of all materials to site including cement, handling charges for the same mixing including placing the pump in position, erecting the horizontal and vertical pipe line to the required distance and height, laying, compacting, providing cover blocks finishing smooth the surface including vibration charges curing concrete all other tools, and plants employed and all other incidental charges etc., complete (Excluding cost and fabrication charges of steel and form work confirming to MoRTH Specifications , as directed by the Engineer. Source MoRTH – Standard Data book for Analysis of Rates, I Revision, Page 472 & 473, Case II)	2898.00	cu.m	485646.84
10	18690.36	kg	Supplying ribbed tor steel or mild steel rods up to 16mm dia including cutting, cranking , fabricating , assembling , laying in exact position , tying with soft steel wire 16 or 18 BWG etc., complete for all RCC works	51.50	kg	962553.54
11	4.76	cu.m	Plain cement concrete 1:1.5:3 (1 cement,1.5 river sand and 3stone jelly 12 to 20mm gauge) including consolidating, curing, etc., complete up to basement	3189.20	cu.m	15180.59
12	2.33	cu.m	Cement concrete work 1:1.5:3 (1 cement 1.5 river sand and 3 blue granite broken stone jelly 12 to 20mm gauge) cast-in-situ including consolidation, curing, etc. ,for all RCC works up to basement.	3478.20	cu.m	8104.21

13	88.13	cu.m	Refilling with excavated earth in regular layers of 15cm thick each including ramming etc., complete	11.11	cu.m	979.12
14	539.07	cu.m	Carting away the surplus earth and debris to a lead of 12km. and dumping in the Corporation land as directed during execution.	67.10	cu.m	36171.60
15	32.00	Nos.	Construction of Inspection Chamber of size 3' x 2' x Flush with 24" FRC Manhole door with frame of Manufacturing, supplying and fixing SFRC manhole cover with frame 600mm dia clear opening heavy duty as per IS:12592/2002. The frame & cover shall bear a non fracture load of 20MT for 30seconds with frame height of 165mm, cover height 90mm, Bearing (Seating area of cover)75mm with Hot Dip Galvanizing Hook of cover 16mm, frame edge protection flat of size 25 x 3mm exposed surface of M.S. rings shall be painted with anti corrosive bitumastic paint. The approximate weight of cover & frame 210kg. Fixing of SFRC doors and Frames with flush levels.	3890.00	E	124480.00
16	18.00	Nos.	Construction of Inspection Chamber of size 3' x 2' x Flush with FRC door and with Gully Gratings of Manufacturing, supplying and fixing SFRC gully gratings 600mm dia with clear width- 12 holes of 50mm dia. The frame & cover shall bear a non fracture load of 5MT for 30seconds with frame height of 165mm (shall confirm IS: 12592/2002), cover height 90mm, Bearing (Seating area of cover)75mm with Hot Dip Galvanizing Hook of cover 16mm, frame edge protection flat of size 25 x 3mm exposed surface of M.S. rings shall be painted with anti corrosive bitumastic paint. The approximate weight of cover & frame 210kg. Fixing of SFRC doors and Frames with flush levels.	4835.00	E	87030.00
17	17.00	M	Supplying and fixing of PVC pipe of 110mm dia (PVC Finolex or Equivalent with ISI Monogram with working pressure of 4Kg/Cm2) for chute pipes	140.00	M	2380.00
18	12.00	M	Supplying and fixing of PVC pipe of 110mm dia (PVC Finolex or Equivalent with ISI Monogram with working pressure of 6Kg/Cm2) for replacing sanitary pipes	210.00	M	2520.00
19	12.00	M	Supplying and fixing of PVC pipe of 160mm dia (PVC Finolex or Equivalent with ISI Monogram with working pressure of 4Kg/Cm2) for Inlet Connections	290.00	M	3480.00
20	12.00	M	Supplying and jointing 20mm dia PVC pipe, including cutting, threading and jointing with necessary specials fixing to wall with clamps and screws including making holes in the wall or drilling holes in roof and making good the wall or roof after fixing with necessary scaffolding etc., complete.	46.60	M	559.20
21	207.74	KG	Supplying and fixing of M.S. Angle of size ISA 75mm x 75mm x 6mm. Provision for service departments cables laying.	42.00	KG	8725.08
TOTAL AMOUNT						2238691.13

Date:
Place:

Signature of the Tenderer
Name and Address of the Tenderer
(IN BLOCK LETTERS)

SCHEDULE.B.

List of Drawings			Supplemental List			
Note: All Drawings to be signed by the contractor as well as the officer entering in to the contract			As referred in the specifications (including the Preliminary specifications of the T.N.B.P/S.S.R.B			
Sl. No.	Drawing No.	Description	Sl. No.	Drawing No.	Description	Date on which the drawing was supplied

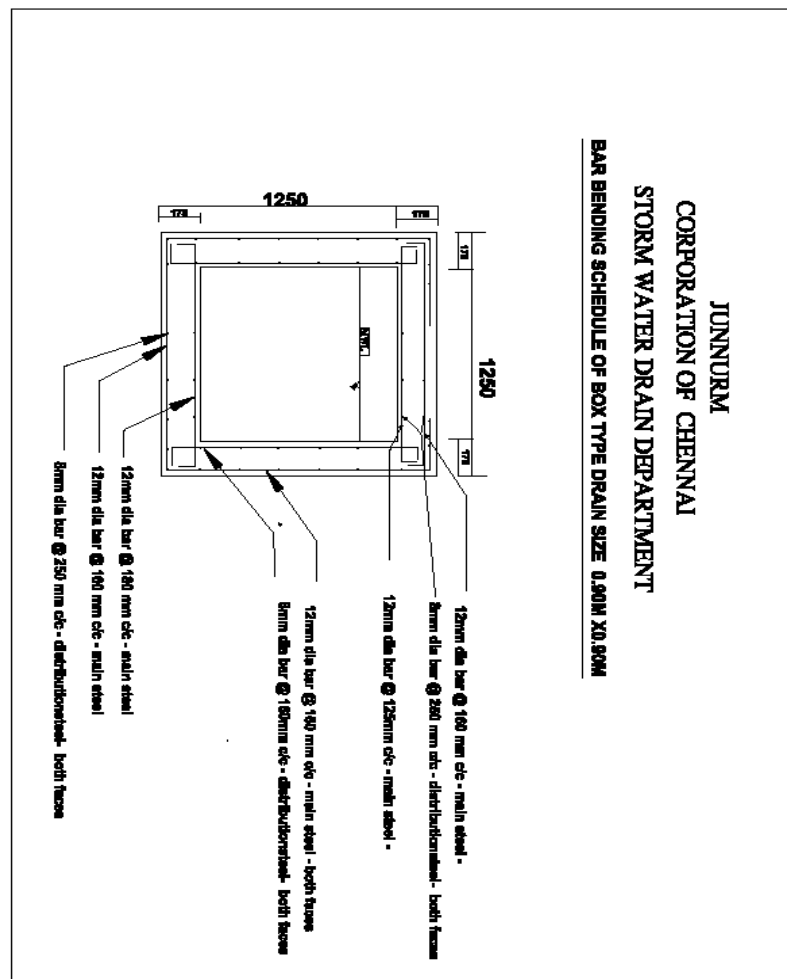

SCHEDULE – C

List of specification for the various items of works supplementing those described in Schedule – A by Standard Specification Numbers

SCHEDULE – D

I/We do hereby agree to execute the works estimated as per the current office schedule of rates for the year **2008-09** contained in this tender schedule with less or higher percentage quoted by me/us as detailed below:

Sl.No.	Name of work	Division /Unit /Zone	Less or higher percentage tendered both in figures and in words
.1	Dismantling 600x750mm and Reconstruction of RCC Box type storm water drain of size 900x900mm along Nallaiah Street from Barrakka Road to Subbarayan Main Street in Dn-59,Zone-IV	Dn-59 Zone-IV	

I/We has/have pursued the schedule of rates attached herewith. Thisless or higher percentage of tendered rate by me/us has to be applicable to each and every individual items of work contained in tender schedule of office schedule of rates attached herewith.

Thisless or higher percentage of quoted rate in this tender is inclusive of all applicable taxes, levies and fees in force.

Important Note to the Tenderer

The Tenderer has to quote the percentage in both words and figures. The tenderer is required to quote up to two decimal points only. If there is any correction in the percentage, it has to be attested by the contractor and also by the officer at the time of opening the tender.

Chennai
Date:

Signature of the Tenderer
Address of the Tenderer

Index to- Preliminary Specifications for works below 2 crores.

S.No.	Description	clause	Page No.
1.	General- Definitions	1-1	26
2.	Corporation	1-1-1	26
3.	Employer	1-1-2	26
4.	Commissioner	1-1-3	26
5.	Superintending Engineer	1-1-4	26
6.	Zonal Executive Engineer	1-1-5	26
7.	Tenderer or Bidder	1-1-6	26
8.	Contractor	1-1-7	26
9.	Plans	1-1-8	26
10.	Specifications	1-1-9	26
11.	Tender Notice	1-1-10	26
12.	Tender Documents or tender forms	1-1-11	26
13.	Contract	1-1-12	26
14.	Work	1-1-13	26
15.	Earnest Money Deposit	1-1-14	26
16.	Security Deposit	1-1-15	26
17.	Conditions	1-2 1	26
18.	Day	1-2-2	26
19.	Party	1-2-3	26
20.	Cleaning up during progress and for Delivery	1-2-4	26
21.	Interpretation of estimates	1-2-5	27
22.	Conformance	1-2-6	27
23.	Rates to include	1-2-7	27
24.	Examination of plans, specifications	1-2-8	27
25.	Approximate	1-2-9	27
26.	Contract Unit Price	1-2-10	27
27.	Carriage	1-2-11	28
28.	Construction plant	1-2-12	28
29.	Temporary Structures	1-2-13	28
30.	Water & lighting	1-2-14	28
31.	Latrines for workers	1-2-15	28
32.	Sun Protection keeping	1-2-16	28
33.	Setting out of works	1-2-17	29
34.	Intent of plans & specifications	1-3-1	29
35.	Increased or decreased quantities	1-3-2	29
36.	Copies of drawings	1-3-3	29
37.	Omitted items	1-3-4	29
38.	Non tendered items	1-3-5	29
39.	Extra work	1-3-6	29-30
40.	Materials & workmanship	1-4-1	30
41.	COC - furnished materials	1-4-2	30
42.	Tests	1-4-3	30
43.	Inspection of materials	1-4-4	30
44.	Defective materials	1-4-5	30-31
45.	Storage materials	1-4-6	31
46.	Measurement & Mixing	1-4-7	31
47.	Authority of S.E & Zonal E.E.	1-4-8	31

48.	<i>Department representative</i>	1-4-9	31
49.	<i>Co-operation by contractor</i>	1-4-10	32
50.	<i>Detailed setting out</i>	1-4-11	32
51.	<i>Inspection of works</i>	1-4-12	32
52.	<i>Uncovering for Inspection</i>	1-4-13	32
53.	<i>Removal of defective & unauthorized work</i>	1-4-14	32-33
54.	<i>Penalty for poor quality of work</i>	1-4-15	33
55.	<i>Contractor to observe laws</i>	1-5-1	33
56.	<i>Public safety</i>	1-5-2	33
57.	<i>Accidents</i>	1-5-3	33
58.	<i>Scaffolding</i>	1-5-4	34
59.	<i>Insurance</i>	1-5-5	34
60.	<i>Remedy to the contractor's failure for insure</i>	1-5-6	35
61.	<i>responsibility for damage claims</i>	1-5-7	35
62.	<i>Protection and restoration of property</i>	1-5-8	35
63.	<i>Contractor's risk</i>	1-5-9	35
64.	<i>Night & Holiday work with permission</i>	1-5-10	35
65.	<i>Execution of work & Progress-Sub-letting and assignment</i>	1-6-1	35-36
66.	<i>Commencement of work</i>	1-6-2	36
67.	<i>Commencement & completion of work</i>	1-6-3	36
68.	<i>Suspension of work</i>	1-6-4	36
69.	<i>Delay & Extension of contract time for completion</i>	1-6-5	36
70.	<i>Determination of contract due default/failure of contractor</i>	1-6-6	37
71.	<i>Forfeiture -partial determination</i>	1-6-7	37
72.	<i>Provision-absolute determination</i>	1-6-8	37-38
73.	<i>Special powers of debarring</i>	1-6-9	38-39
74.	<i>Measurement & payment of measured quantities</i>	1-7-0,1-7-1	39
75.	<i>Final payment</i>	1-7-2	39
76.	<i>Non tendered items</i>	1-7-3	39
77.	<i>Payment extra items</i>	1-7-4	39-40
78.	<i>Accounts , receipts and vouchers</i>	1-7-5	40
79.	<i>Fraud, will full neglect or default</i>	1-7-6	40
80.	<i>Unfixed materials</i>	1-7-7	40
81.	<i>Payment & certificates</i>	1-7-8	40
82.	<i>Acceptance of Final measurement</i>	1-7-9	40
83.	<i>Recoveries from contractor</i>	1-7-10	40
84.	<i>Safety code</i>	1-8-1	40-41
85.	<i>Excavation & trenching</i>	1-8-2	41
86.	<i>Demolition</i>	1-8-3	41
87.	<i>Safety equipments</i>	1-8-4	41
88.	<i>First aid provision</i>	1-8-5	42

89.	<i>Use of Hoisting</i>	1-8-6	42
90.	<i>Risk coverage</i>	1-8-7	42
91.	<i>Maintenance of Equipments</i>	1-8-8	42
92.	<i>Safety measures</i>	1-8-9	42
93.	<i>Enforcement of rules</i>	1-8-10	42
94.	<i>No exemption to contractor</i>	1-8-11	42
95.	<i>Providing insurance</i>	1-9	42
96.	<i>General Conditions Civil Works</i>	2	42
97.	<i>Traffic regulations</i>	2-1to 2-4	42-43
98.	<i>Procedure for work & payment</i>	2-5	43
99.	<i>Lump sum items</i>	2-6	43
100.	<i>Inconvenience to public</i>	2-7	43
101.	<i>Removal of covering</i>	2-8	43
102.	<i>Charges to be paid by contractor</i>	2-9	44
103.	<i>Traffic regulations, Other regulations , specifications etc</i>	2-10 to 2-34	44-46
104.	<i>Site Instruction Book</i>	2.35	46
105.	<i>Application form-for permission (Night&H/Day)</i>	2.36	47
106.	<i>General Specifications-Materials-general-Prov.</i>	3.1 to 3.34	48-56